



## **USER GUIDE**

**BELLING VISION 90CM DUAL-FUEL SINGLE OVEN MODELS**

## Table Of Contents

INTRODUCTION .....	3
MODELS COVERED BY THIS DOCUMENT .....	3
COUNTRIES OF DESTINATION: .....	3
CONTACT INFORMATION: .....	3
EUROPEAN DIRECTIVES .....	4
DISPOSAL OF PACKAGING MATERIAL .....	4
SAFETY & WARNING INFORMATION .....	5
GAS HOB: DO's & DON'Ts .....	12
GETTING TO KNOW YOUR NEW APPLIANCE .....	13
BEFORE FIRST USE .....	13
APPLIANCE OVERVIEW .....	13
OVERVIEW OF CONTROL PANEL .....	14
OVERVIEW OF GAS HOB .....	14
IGNITION PROCEDURES .....	15
IGNITION OF GAS BURNERS .....	16
AUTOMATIC IGNITION .....	16
USING THE WOK CRADLE .....	16
OVERVIEW OF OVEN FURNITURE .....	17
OVEN OVERVIEW .....	20
GRILL PANS AND TRIVETS .....	23
USING THE STORAGE DRAWER .....	24
USING THE PROGRAMMABLE TIMER .....	26
CLEANING YOUR APPLIANCE .....	30
CLEANING AND CARE GUIDANCE .....	31
APPLIANCE MAINTENANCE .....	35
CHANGING THE LIGHTBULBS .....	35
OVEN SHELVES .....	37
REMOVING AND REPLACING SHELF GUIDES .....	37
REMOVING AND RE-FITTING CONTROL DIALS, SPRINGS AND BEZELS .....	38
REMOVING THE INNER GLASS PANELS FOR CLEANING .....	39
FAQ's .....	42
KEY PARTS AND OPTIONAL ACCESSORIES .....	46
FITTING THE DECORATIVE COVER PLINTH .....	53
LOCATING THE MODEL AND SERIAL NUMBERS .....	54
TECHNICAL DATA .....	55
ENERGY DATA TABLE .....	58
ENERGY SAVING TIPS FOR HOB'S .....	59
ENERGY SAVING TIPS FOR OVENS .....	59
SERVICE CONTACT DETAILS .....	60

# INTRODUCTION

Congratulations and thank you for purchasing your new cooking appliance. We hope you will enjoy many years of excellent cooking performance and service.

This user guide is designed to help you care for and get the best out of your new appliance.

Please read it carefully before you start using your appliance, as we have endeavoured to answer as many questions as possible and provide you with as much support as we can.

General information, spares and service information is available from our website.

If you should find something missing from your product or have any questions that are not covered in this user guide, please contact us (see contact information on the back cover).

NL - Netherlands	
PL - Poland	
SE - Sweden	
AU - Australia	
NZ - New Zealand	

## CONTACT INFORMATION:

**Customer Care Helpline:**

**0344 815 3746**

**Alternatively, use the contact form on our website**

**[www.belling.co.uk](http://www.belling.co.uk)**

**Details about warranty registration and spares & service information are also available on our website.**

## MODELS COVERED BY THIS DOCUMENT

**Models Covered by This Document:**

<b>Model Number:</b>	<b>Model Description:</b>
444412039	BEL RCA VISION SGL 90DF BLK
444412040	BEL RCA VISION SGL 90DF BSS

Calls are charged at the basic rate, please check with your telephone service provider for exact charges.

Your new appliance comes with our FREE 3 year warranty (UK only), protecting you against electrical and mechanical breakdown.



## COUNTRIES OF DESTINATION:

GB- United Kingdom	✓
IE - Ireland	✓
BE - Belgium	
DE - Germany	

To register your new appliance for its warranty (UK only) please visit our website [www.belling.co.uk](http://www.belling.co.uk). For full terms & conditions of the manufacturer's guarantee, please refer to the website above.

In addition, you may wish to purchase an extended warranty. Details of how to do this are also on our website [www.belling.co.uk](http://www.belling.co.uk).

Our policy is one of constant development and improvement, therefore we cannot guarantee the strict accuracy of all of our illustrations and specifications. Changes may have been made subsequent to publishing.

Glen Dimplex Home Appliances, Element,  
Temple Court, Risley, Warrington, WA3 6GD.

## EUROPEAN DIRECTIVES

This appliance is produced in accordance with all applicable local and international standards and regulations.

As a producer and a supplier of cooking appliances we are committed to the protection of the environment and are in compliance with the WEEE directive.

All our electric products are labelled accordingly with the crossed out wheeled bin symbol. This indicates, for disposal purposes at the end of their working life, that these products must be taken to a recognized collection point, such as local authority sites/ local recycling centres.



**Some of the materials used to package this appliance can be recycled. Please dispose of the packaging materials in the appropriate containers at your local waste disposal facility.**

By ensuring that this product is disposed of correctly, you will help prevent potential negative consequences for the environment and human health, which could otherwise be caused by inappropriate waste handling of this product.

For more detailed information about recycling of this product, please contact your local authority, household waste disposal service, or the retailer from whom you purchased this appliance.

This appliance complies with European Community Directives (CE) for household and similar electrical appliances and Gas appliances where applicable.

This appliance conforms to European Directive regarding Eco design requirements for energy-related products. Our policy is one of constant development and improvement, therefore we cannot guarantee the strict accuracy of all of our illustrations and specifications - changes may have been made subsequent to publishing.

## DISPOSAL OF PACKAGING MATERIAL

# SAFETY & WARNING INFORMATION

Please read the following information carefully:

## WARNINGS



### Warning

**This appliance must be connected by a competent person who is a member of a 'Competent Person Scheme', who will comply with the required regulations.**

**Any servicing, maintenance or repair work on the appliance must only be carried out by authorised personnel.**

**Installation, maintenance and repair work that is carried out by unauthorised persons could be dangerous and could invalidate the manufacturer's warranty.**



### Warning

**This appliance can be used by children aged from 8 years and above and persons with reduced physical, sensory or mental capabilities or lack of experience and knowledge if they have been given supervision or instruction concerning use of the appliance in a safe way and understand the hazards involved.**

**Children shall not play with the appliance.**

**Cleaning and user maintenance shall not be made by children without supervision.**

**Young children should be supervised to ensure they do not play with this appliance.**

**Do not store items of interest to children in cabinets above the appliance. Children climbing on the appliance could be seriously injured.**



### Warning

**If the hotplate surface is cracked, switch off the appliance and do not use it to avoid the possibility of electric shock.**

**Warning**

During use the appliance becomes hot. Care should be taken to avoid touching heating elements inside the oven.

**Warning**

Metallic objects such as knives, forks, spoons and lids should not be placed on the hob surface since they can get hot.

Any spillage should be removed from the lid before opening and the hob surface should be allowed to cool before closing the lid.

**Warning**

The appliance and its accessible parts become hot during use.

Care should be taken to avoid touching heating elements, and hot external and internal surfaces, including doors.

Use oven gloves.

Children less than 8 years of age shall be kept away unless continuously supervised.

**Warning**

Ensure that the appliance is switched off before replacing the lamp to avoid the possibility of electric shock.

**Warning**

The cooker must be switched off before removing the guard and, after cleaning, the guard must be replaced in accordance with the instructions.

**Warning**

Unattended cooking on a hob with fat or oil can be dangerous and may result in fire. Risk of burns and scalds.

**NEVER** try to extinguish a fire with water, but switch off the appliance and then cover the flames e.g. with a lid or a fire blanket.

**Warning**

A steam cleaner is not to be used on this appliance.

**Warning**

Danger of fire: do not store items on the cooking surfaces or in the oven cavities.

**Warning**

Use only hob guards designed by the manufacturer of the cooking appliance or indicated by the manufacturer of the appliance in the instructions for use as suitable or hob guards incorporated in the appliance. The use of inappropriate guards can cause accidents.

**Warning**

Do not store or use flammable liquids or items in the vicinity of this appliance.

Do not allow curtains, paper or other flammable items to come into contact with the cooker.

Do not spray aerosols in the vicinity of the appliance while it is in operation.

**Warning**

Never place food, or dishes on the base of the main oven, the element is here, and it will cause overheating.

**Warning**

Do not modify this appliance.

**Warning**

Do not place articles on or against the appliance.

**Warning**

Do not operate the appliance without the glass door panels correctly fitted.

**Warning**

The appliance must never be disconnected from the mains supply during use, as this will seriously affect the safety and performance, particularly in relation to surface temperatures becoming hot and gas operated parts not working efficiently.

The cooling fan (if fitted) is designed to run on after the control knob has been switched off.

**Warning**

Accessible parts may become hot when the grill is in use. Children should be kept away.

**Warning**

If a lid is fitted to your appliance any spillage should be removed from the lid before opening and the hob surface should be allowed to cool before closing the lid.

**Warning**

This appliance must be earthed.

**Warning**

The grill **MUST** be used with the door **CLOSED**.

**Warning**

This appliance must not be used as a space heater.

**Warning**

Never use cooking vessels on the hob that overlap its edges.

Saucepan handles may become hot during use.

Keep pan handles out of the reach of children.

**Warning**

If the electrical connection cable becomes damaged, it must be replaced by a suitably-qualified person.

The cable must not be replaced by an unauthorised person.

**Warning**

**GAS WARNING!** - If you smell gas even though the appliance controls are turned off:

Do not try to ignite any gas appliance; do not smoke; do not use any naked flames.

Do not touch any electrical switches or use a mobile telephone.

Open doors and windows to ventilate the property. Evacuate people and pets to fresh air outside a safe distance away from the property.

Switch the gas supply off using the emergency isolation valve at the gas meter.

Telephone the local gas emergency service immediately from a neighbour's property or use a mobile phone outside a safe distance away from the property.

In Great Britain telephone 0800 111 999; in Northern Ireland telephone 0800 002 001; in the Republic of Ireland telephone 1800 20 50 50; in the Isle of Man telephone 0808 1624 444; in Jersey telephone 01534 755555; in Guernsey telephone 01481 749000.

Do not re-enter the property until the emergency engineer has attended and has advised it is safe to do so.



### **Warning**

**This appliance must be installed in accordance with the regulations in force and only used in a well-ventilated space.**

**Read the instructions before installing or using this appliance.**

**Prior to installation, ensure that the local distribution conditions (the gas type and gas pressure) and adjustment of the appliance are compatible.**

**The adjustment conditions for this appliance are stated on the label or data badge.**

**This appliance is not connected to a combustion products evacuation device. It shall be installed and connected in accordance with current installation regulations. Particular attention shall be given to the relevant requirements regarding ventilation.**

## **CAUTIONS**



### **Caution**

**In order to avoid a hazard due to inadvertent resetting of the thermal cut-out, this appliance must not be supplied through an external switching device, such as an external timer, or connected to a circuit that is regularly switched on and off by the utility.**



### **Caution**

**Do not use harsh abrasive cleaners or sharp metal scrapers to clean the oven door glass / the hob surface / the glass of hinged lids of the hob (as appropriate), since they can scratch the surface, which may result in shattering of the glass.**

**Always ensure that the appliance is switched off before cleaning or carrying out user maintenance.**

**Do not clean the appliance with a steam cleaner.**

**Always clean up food spillages immediately, after switching the appliance off, taking care to avoid burning yourself.**

**Do not use scourers, sharp metal scrapers or any abrasive or corrosive cleaning agents - risk of damage and glass breakage.**

**Do not remove the data badge labels or clean them with corrosive cleaners.**

**Do not stand on the hob surface.**

**Do not allow any part of your body, hair, clothing, etc. to come into contact with the hob surface until it has cooled.**



### **Caution**

**Only use the temperature probe recommended for this oven.**

**Caution**

After use, switch off the hob burner by its control knob.

After use, ensure that all touch controls are switched off and that all control knobs are in the off position.

**Caution**

Our policy is one of constant development and improvement, therefore we cannot guarantee the strict accuracy of all of our illustrations and specifications. Changes may have been made subsequent to publishing.

**Caution**

This appliance is not intended to be operated by means of an external timer or separate remote control system.

**Caution**

Make sure that you have removed all packaging and wrapping from the outside and inside of the appliance before it is used.

**Caution**

The cooking process must be supervised. A short-term cooking process has to be supervised continuously.

Some of the items inside this appliance may have additional wrapping.

It is advised that you turn the ovens and/or grill on for a short while. This will burn off any residues left from manufacturing. There may be a smell which accompanies this process - but this is nothing to worry about and is harmless.

**Caution**

Accessible parts may be hot when the grill and/or the oven are in use. Young children shall be kept away.

It is recommended that you wash the oven shelves, grill pan, and grill pan trivet before their first use in hot soapy water. This will remove the protective oil coating used during storage.

**Caution**

When using the grill, the oven door must be kept **CLOSED**.

**Caution**

**This appliance is designed for cooking purposes only. It must not be used for other purposes, for example room heating.**

**Caution**

**When opening oven doors, grip the handle in the centre and hold it from underneath.**

**Caution**

**Do not cover the appliance.**

**Caution**

**Take care if moving the appliance, panel edges could be sharp. Failure to use caution could result in injury or cuts. Do not attempt to lift or move the appliance by pulling on the door handles.**

**Caution**

**If you will not be using the appliance for some time, switch off the power supply at the isolator switch on the wall.**

**Caution**

**The use of gas cooking appliances results in the production of heat, moisture and products of combustion in the room in which it is installed. Ensure that the kitchen is well-ventilated, especially when the appliance is in use.**

**Prolonged, intensive use of the appliance may require additional ventilation, for example increasing the rate of mechanical ventilation where present or opening windows, to safely remove the products of combustion to the outside (external) air whilst also providing additional ventilation for room air changes.**

**Consult a professional before installing additional ventilation.**

## OTHER SAFETY ADVICE

### DO

- Always take care when removing food from the oven as the area around the cavity may be hot.
- Always use oven gloves when handling any cookware that has been in the oven as it will be hot.
- Always make sure that the oven shelves are resting in the correct position between two runners.
- Always use the Minute Minder (if fitted) if you are leaving the oven unattended - this reduces the risk of food burning.

### DO NOT

- Never place dishes or other items on the door while it is open. Do not apply downward pressure to open oven doors. Do

not allow children to climb onto open oven doors. Do not slam the oven doors shut. When shutting oven doors, ensure there is nothing obstructing them from closing. Risk of breakage.

- Never wrap foil around the oven shelves or allow foil to block the flue. Do not line the oven cavities or grill pan with aluminium foil - risk of fire. Do not use liners on the oven floors - risk of build-up of trapped heat which can cause permanent damage to the oven enamel.
- Never drape tea towels, dishcloths or clothes, etc. near the oven or from the door handles while it is on; this will cause a fire hazard.
- Never pull heavy items, such as turkeys or large joints of meat, out from the oven on the shelf, as they may overbalance and fall.
- Never use this appliance to heat anything other than food items and do not use it for heating the room.

#### **FIRE SAFETY ADVICE**

Most kitchen fires occur when people are distracted or leave things unattended. Don't let yourself be distracted while cooking. If you're called away from the cooker, either take pans off the heat, or switch off your hob.

If you do have a fire in the kitchen, don't take any risks - get everyone out of your home and call the Fire Brigade.

If a pan catches fire:

- Do not move it - it is likely to be extremely hot.
- Turn off the heat if it's safe to do so - but never lean over a pan to reach the controls.
- If you have a fire blanket, put it over the pan. If you have put the fire out, leave the pan to cool completely.

Deep-fat frying presents more dangers in your kitchen.

- Never fill a chip pan (or other deep fat fryer) more than one-third full of oil.
- Do not use a fire extinguisher on a pan of oil - the force of the extinguisher can spread the fire and create a fireball.

If you have an electrical fire in the kitchen:

- Pull the plug out, or switch off the power at the fuse box - this may be enough to stop the fire immediately.
- Smother the fire with a fire blanket, or use a dry powder or carbon dioxide extinguisher.
- Remember: never use water on an electrical or cooking oil fire.

## **GAS HOB: DO'S & DON'TS**

### **DO**

- Always ensure that pan bases are dry and flat before using them on the hob.
- Always position pans over the centre of the heat zone, and turn the handles to a safe position so they cannot be knocked or grabbed.
- Always use pans which are no smaller than 100mm (4"), or larger than 250mm (10"). Use a 230 mm (9") pan above the wok burner, if two or more other hotplate burners are in use at the same time.
- Always match the size of pan to the heat zone - do not use large pans on small zones or vice versa. • Always make sure that the burner caps, rings and pan supports are correctly placed. This will prevent pans becoming unstable while in use and ensure an uninterrupted gas flow.

### **DO NOT:**

- Never use double pans, rim-based pans, old or misshapen pans, or any pan that is not stable on a flat surface.
- Never leave cooking fat, or oil, unattended.
- Never use commercial simmering aids, or heat diffusers, as they create excessive heat and can damage the surface of the hob.
- Plastic cooking utensils can melt if they come into contact with a warm hob. Never leave them close to, or on top of the hob.
- Never leave any heat zone alight without a pan covering it. This causes a fire hazard.
- Never leave an empty pan on a heating zone.
- Never leave anything lying on the hob.
- Never heat a sealed tin of food, as it might explode.
- Never use the hob surface for storage.

# GETTING TO KNOW YOUR NEW APPLIANCE

The layout of your appliance may differ from the drawings shown in this guide depending on the model.

## BEFORE FIRST USE

Before using the cooker for the first time:

- Take a photograph of the data badge on the appliance, or make a written note of the model number and serial number.
- Ensure that all packaging and loose accessories have been removed from the appliance, remembering to check inside the oven compartment(s) and storage compartment if applicable.
- Ensure that the burner skirts, burner caps and pan supports have been positioned correctly on the hotplate.
- Set the time of day on the timer clock and ensure that no digits or symbols are flashing on the display.
- Heat the oven(s), empty of food or cookware, at 180°C for at least 30 minutes to allow the oils used to protect the cooker

in storage to burn off. Keep the kitchen well-ventilated during this procedure.

- Download the full online user guide from the website.
- Register the appliance on the website.

## APPLIANCE OVERVIEW

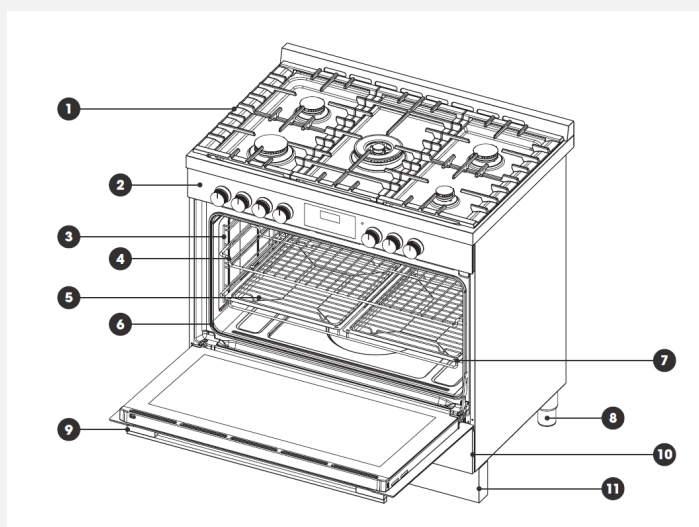

Key	Description
1	Gas hob hotplate
2	Control panel
3	Shelf guides
4	Oven shelf
5	Grill pan trivet
6	Door seal
7	2 x grill pans and holder. The grill pans can also be used as baking trays and roasting tins.
8	Height-adjustable legs
9	Door handle
10	Storage drawer
11	Decorative cover plinth

## OVERVIEW OF CONTROL PANEL



Key	Description
1	Hob control for front-left burner
2	Hob control for back-left burner
3	Hob control for central burner
4	Oven function selector control - used in conjunction with 6
5	Programmable timer - controls the oven
6	Oven temperature selector control - used in conjunction with 4
7	Oven heating indicator lamp
8	Hob control for back-right burner
9	Hob control for front-right burner

## OVERVIEW OF GAS HOB

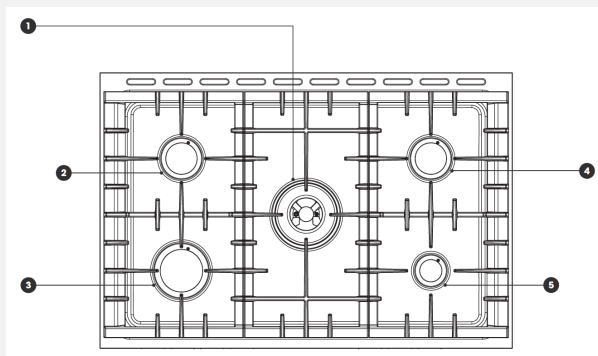

Key	Description	Location	Power	Recommended pan diameter sizes
1	Wok burner	Centre	3.8 kW	Minimum 210mm - maximum 260mm
2	Medium burner	Back-left	1.75 kW	Minimum 130mm - maximum 180mm
3	Large burner	Front-left	3.0 kW	Minimum 150mm - maximum 260mm
4	Medium burner	Back-right	1.75 kW	Minimum 130mm - maximum 180mm
5	Small burner	Front-right	1.0 kW	Minimum 90mm - maximum 160mm

Pans must have smooth, flat, stable bases. Please centre the pans on the burners.

Choose a burner relevant to the size of the pan. Do not exceed the maximum recommended pan sizes. Do not allow the flames to lip out beyond the edge of the pan.

## OVERVIEW OF THE GAS HOB CONTROL DIAL

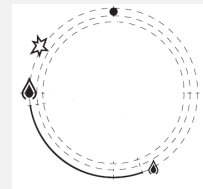

Symbol	Description
█	Off position
★	Spark/ignition position
🔥	Maximum flame position
🔥	Minimum flame position



### Warning

Do not position the hob control dial between the maximum flame position and the off position during use.

## IGNITION PROCEDURES

## IGNITION OF GAS BURNERS

Correct procedure for ignition of all gas burners on this appliance:

### PRIOR TO IGNITION:

- Position correctly sized, flat bottomed pan(s) directly onto the pan support(s) above the selected burner(s).

### WOK BURNER

- Position a flat-bottomed wok or a correctly sized, flat-bottomed pan directly onto the pan support above the wok burner.

## AUTOMATIC IGNITION

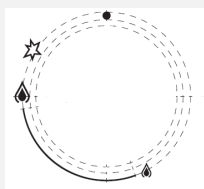

- Push in and turn the selected gas burner control knob to the full flame symbol. Keep the control knob depressed. Sparking to the selected burner will commence automatically. Sparking will cease automatically once the flame is established. Continue to hold the control knob in for up to 15 seconds after the flame has lit before releasing; this will allow time for the flame safety device to warm up.
- If the burner fails to ignite within this time, turn the control knob back to the off position, release it and wait 1 minute before attempting to re-ignite.
- In the event of a power failure, or the ignition not working, then a lighted taper or gas lighter can be used to ignite the burner.

- Use pans which are large enough to avoid overflows onto the hob surface.
- Keep pan handles turned away so that pans cannot be accidentally knocked over.
- Ensure that pans are sturdy and have flat bases.
- Wipe up any spillage as soon as possible.
- Clean the hob top as regularly as possible, this will prevent any build up of grease which may be a fire hazard.



## USING THE WOK CRADLE

The wok support cradle is designed to support round-bottomed woks when stir-frying.

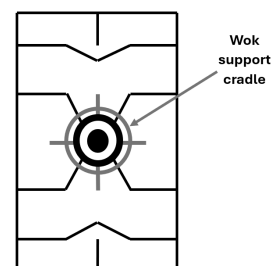

Place the wok support cradle securely over the centre of the wok pan support, as shown.

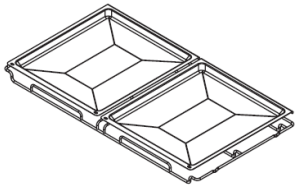
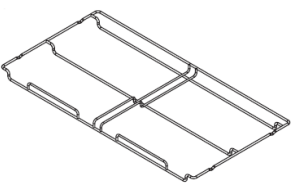

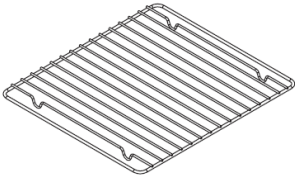
## OVERVIEW OF OVEN FURNITURE

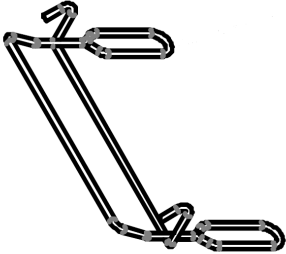
Item	Quantity supplied with cooker	Notes
 <p><b>Grill-pan</b></p>	2	<p>Can also be used as baking trays or roasting tins.</p> <p>The grill pans are inserted sideways into the grill pan holder, before the holder is inserted into the shelf guides in the oven.</p> <p>Ensure that the lip of the grill pan is hooked over the rear wire of the holder for stability.</p>
 <p><b>Grill-pan holder</b></p>	1	<p>Place the grill pans sideways into the grill pan holder.</p> <p>Ensure that the lip of the grill pan is hooked over the rear wire of the holder for stability.</p> <div data-bbox="762 1104 1385 1429" style="background-color: #f0f0f0; padding: 10px; border: 1px solid #ccc;"> <p> <b>Warning</b>            Always use oven gloves and exercise caution when removing the grill-pan holder and grill pans from a hot oven.</p> </div>
 <p><b>Grill-pan trivet</b></p>	2	<p>Place the trivets inside the grill pans to support the food when grilling.</p>

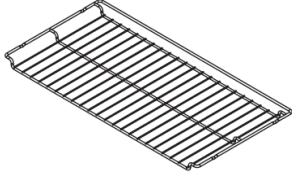
Item	Quantity supplied with cooker	Notes
 <p data-bbox="209 714 427 745">Grill-pan handle</p>	1	<p data-bbox="762 378 1326 450">Used when inserting and withdrawing the grill-pans on the holder.</p> <p data-bbox="762 488 1310 557">Position the grill-pan handle centrally to securely attach it to both grill-pans.</p> <p data-bbox="762 595 1347 701">The wide area of the grill-pan handle is placed underneath the grill-pans, while the prongs attach to the top of the grill-pans.</p> <div data-bbox="762 770 1385 1357" style="background-color: #f0f0f0; padding: 10px; border: 1px solid #ccc;"> <p data-bbox="804 819 871 875"></p> <p data-bbox="900 819 1046 853"><b>Warning</b></p> <p data-bbox="916 864 1358 1126"><b>Do not leave the grill-pan handle attached to the grill-pans during grilling, as the handle could get very hot and the oven door needs to be fully closed when grilling.</b></p> <p data-bbox="916 1162 1355 1308"><b>Do not attempt to carry hot grill-pans using the grill-pan handle - risk of burns, scalding and injury.</b></p> </div>

Item	Quantity supplied with cooker	Notes
 <p data-bbox="209 645 280 674">Shelf</p>	<p data-bbox="576 383 596 412">2</p>	<p data-bbox="762 383 1289 450">There are 5 shelf positions for the oven shelves.</p> <p data-bbox="762 488 1342 555">Insert the shelf with the anti-tip notches at the back and facing downwards.</p> <div data-bbox="762 624 1385 1211" style="background-color: #f0f0f0; padding: 10px; border: 1px solid #ccc;"> <p data-bbox="804 674 871 730"></p> <p data-bbox="900 674 1046 712"><b>Warning</b></p> <p data-bbox="916 719 1331 904"><b>Insert the shelf between the two wires of the shelf guide position, not on top of the upper wire - danger of scalding or injury.</b></p> <p data-bbox="916 943 1342 1160"><b>Do not attempt to place a shelf on top of the shelf guides as the shelf will not be held in a stable position and could tip out - danger of scalding or injury.</b></p> </div> <p data-bbox="762 1279 1382 1391">When removing a shelf for cleaning, wait for the shelf to cool, then pull it outwards and lift it upwards to remove it completely.</p> <p data-bbox="762 1429 1299 1496">The useable shelf area is approximately 761mm wide by 390mm deep.</p>

## OVEN OVERVIEW

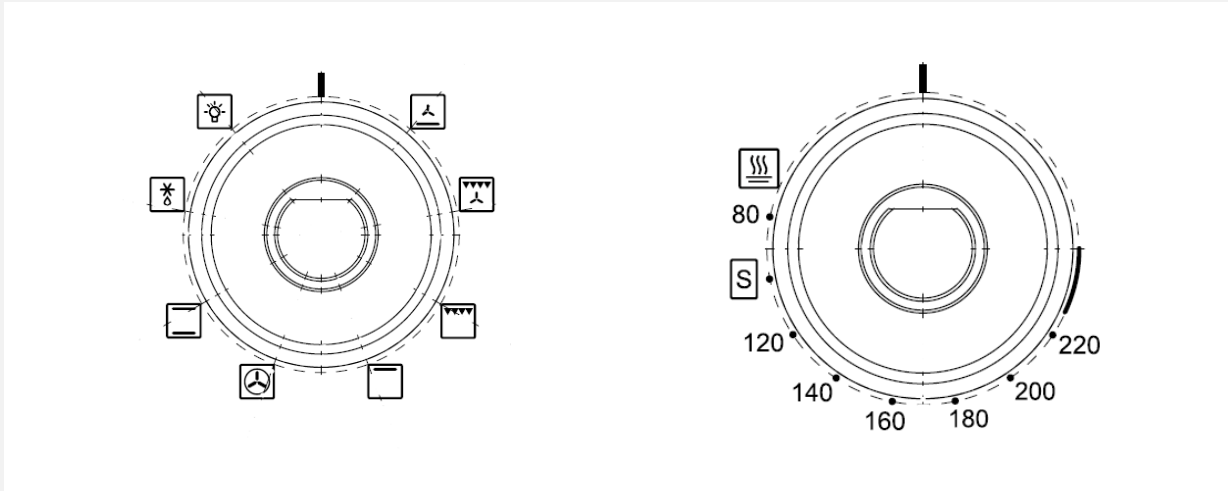

Turn the oven function control knob (shown on the left) clockwise or anti-clockwise to the cooking function required.

Turn the oven temperature control knob (shown on the right) clockwise to the temperature or setting required.

Turn the oven off by turning the function and temperature control knobs anti-clockwise back to the '12 o'clock' off position.

## OVEN COOKING FUNCTIONS AND SETTINGS















### Note

The time of day must be set on the timer before the oven can be used.

As this is a multi-functional oven, both a function and a temperature must be selected before the oven will start to heat up.

Symbol	Description
	<p>Lamps only function (without heating on).</p> <p>Useful to provide extra visibility when wiping around the oven compartment.</p> <p>Leave the temperature selector control knob in the 'off' position.</p>

Symbol	Description
	<p><b>Defrost function (without heating on).</b></p> <p>Use with the door closed to defrost frozen items such as bread and gateaux. Place the grill pan below the shelf to catch drips.</p> <p>Use with the door closed for proving dough prior to baking.</p> <p>Leave the temperature selector control knob in the 'off' position.</p>
	<p><b>Conventional oven function.</b></p> <p>Useful for traditional baking and roasting.</p> <p>For best results, pre-heat the oven for up to 15 minutes, cook on one level only and use the middle shelf position. The oven will be a bit hotter at the top and a bit cooler at the bottom.</p>
	<p><b>True fanned oven function.</b></p> <p>Provides an even temperature distribution throughout the oven cavity.</p> <p>Use any suitable shelf position, and can bake on two or more levels simultaneously, remembering to allow space for baking to rise.</p> <p>Generally does not require pre-heating.</p> <p>Reduce the temperature by around 20°C and reduce the cooking time a little compared to conventional ovens.</p>
	<p><b>Top heat function.</b></p> <p>Often used towards the end of the cooking process to brown dishes like shepherd's pie, lasagne, cauliflower cheese, etc.</p> <p>For best results, place the food on a middle shelf position to avoid over-browning.</p>
	<p><b>Conventional grill function.</b></p> <p>Useful for toasting bread and grilling thinner meats, like bacon.</p> <p>Pre-heat for 3-5 minutes for best results.</p> <p>Use a suitable medium-to-high shelf position, but ensure that the food will not come into contact with the heating element.</p> <p>Use with the door closed.</p>

Symbol	Description
	<p><b>Fan-assisted grill function.</b></p> <p>Useful for circulating heat around thicker meats, like sausages and chicken pieces without the need to turn the food as often.</p> <p>Pre-heat for 3-5 minutes for best results.</p> <p>Use a suitable medium-to-high shelf position, but ensure that the food will not come into contact with the heating element.</p> <p>Use with the door <b>closed</b>.</p>
	<p><b>Base heat with fan function.</b></p> <p>Useful for baking open pies and tarts or baking pastry cases, etc.</p> <p>For best results, pre-heat the oven for up to 15 minutes, cook on one level only and use the middle shelf position.</p>
	<p><b>Keep warm function (70°C).</b></p> <p>For keeping food warm prior to serving.</p> <p>Can be used for warming plates - place plates on the shelves. Do not place plates on the floor of the oven cavity.</p> <p>Select the fanned function  or conventional function  on the function selector.</p>
	<p><b>Slow cook function (100°C).</b></p> <p>For slow cooking of casseroles, stews, etc.</p> <p>Select the fanned function  or conventional function  on the function selector.</p>
80°C to 220°C	The temperature settings for the oven (80°C to 220°C).



### Important

When using the grill function, the door must be kept closed.



### Tip

The grill is designed to be used with the door closed for quicker heat-up times and more efficient grilling.

## OVEN SHELF POSITIONS

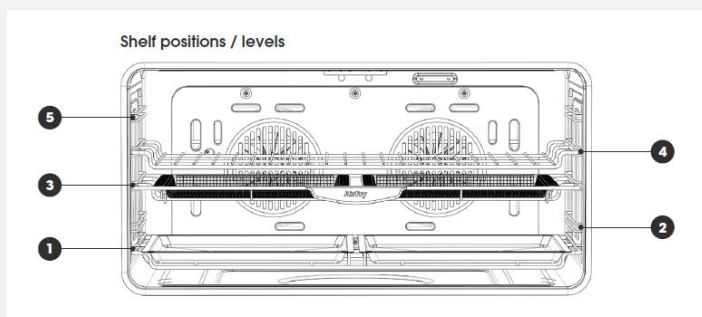

## GRILL PANS AND TRIVETS



### Note

- **The oven may give off an unusual odour when first used, as the oils used to protect the oven enamel in storage are being burnt off.**
- **Ventilate the kitchen and heat the oven, without food in it, at 180°C for approximately two hours to remove any smell.**
- **Once the oven has cooled down, clean the oven interior, shelves, guides and grill-pan with warm soapy water before using the oven to cook.**

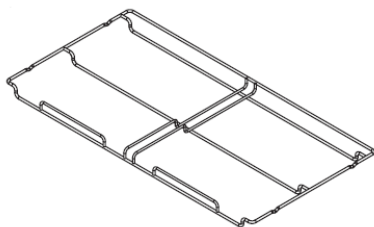

**Holder for the grill-pans**

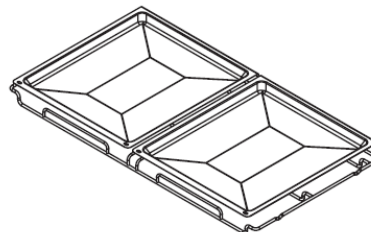

**Grill-pans located in the holder**

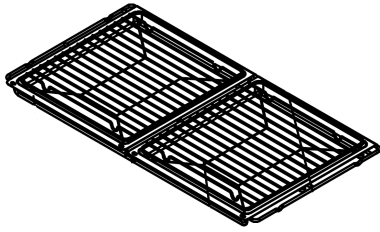

Trivets inserted in the grill-pans

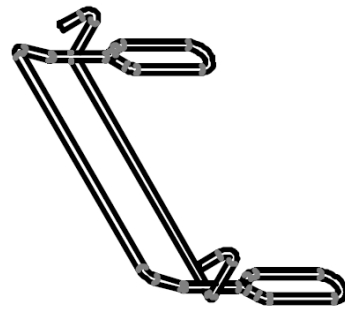

Grill-pan handle

The cooker is supplied with two grill-pans and two trivets. The trivets sit inside the grill-pans.

The grill-pans fit length-ways into a wire holder which is then inserted into the shelf guides.

When inserting the grill-pans into the holder, for safety and stability ensure that the lip of the grill-pan is positioned over the wire at the back of the holder.

The grill-pan handle clips over the front of the grill-pans. Ensure that the grill-pan handle prongs are at the top, and the wider support piece sits underneath the grill-pans.

When using both of the grill-pans, ensure that the grill-pan handle is located centrally so that it can be safely used to withdraw both grill-pans together.



**Warning**

The grill-pan handle is designed for sliding the grill-pans in and out. Do not attempt to carry the grill pans by the handle.



**Warning**

The oven door must be kept closed when the grilling.

## USING THE STORAGE DRAWER

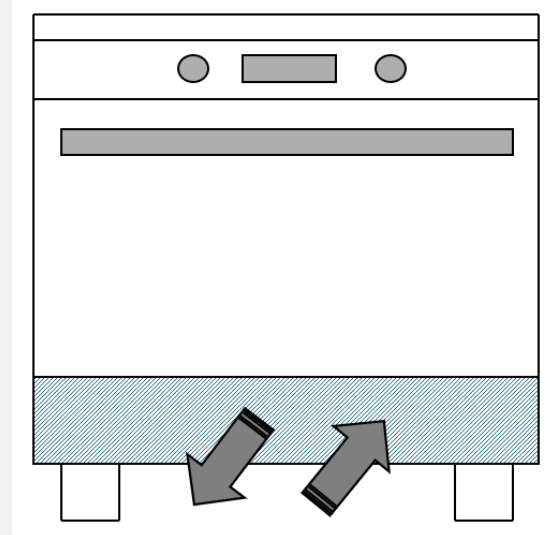

Gently pull on the underside front panel to open the storage drawer.

Gently push on the front panel to close the storage drawer.

The useable space of the storage drawer is approximately 813mm wide by 370mm deep by 50mm high.

Only use the storage drawer for storing non-flammable items such as bakeware.



### **Caution**



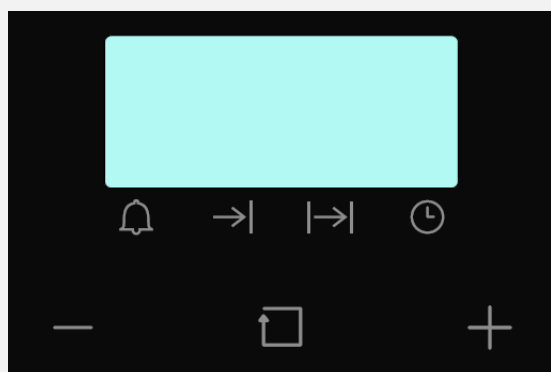

**The storage drawer must not be used to store flammable items or objects that cannot withstand heat (including paper, timber, aerosol sprays, cloths, tea towels, cleaning materials, etc).**

**The storage drawer is not designed for cooking or for keeping cooked food warm. Risk of food poisoning.**

# USING THE PROGRAMMABLE TIMER



## Timer Symbols

Symbol	Description
	Minute minder
	Cooking duration time
	End of cooking time
	Time of day

## Timer Touch Controls

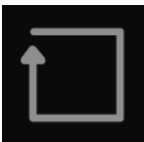
Touch Control Symbol	Description
	Minus key - to decrease time value
	Function key - to scroll through the timer functions

Touch Control Symbol	Description
	Plus key - to increase time value









### Tip

Touching and holding the plus key/minus key makes the time value increase/decrease more quickly.

## MANUAL MODE













- The main oven can be used manually, that is without the timer switching the main oven off automatically, or on and off automatically.
- The time of day must be set on the timer before using the main oven manually.

## SETTING THE TIME OF DAY

- When the cooker is first connected to the power supply the time display shows '12:00' and the bar above the clock symbol  flashes.
- Use the plus  and/or minus  keys to set the current time of day using the 24 hour clock.
- A few seconds after the last key touch, the time of day will be accepted and the main oven can be used manually.
- If you need to adjust the time of day, for example at the start and end of daylight saving time, touch the function key  repeatedly (usually four touches) until the bar above the clock symbol  flashes.
- While the bar is flashing, use the plus  and/or minus  keys to set the correct time of day using the 24 hour clock.

















- A few seconds after the last key touch, the time of day will be accepted and the bar will stop flashing.

## USING THE MINUTE MINDER

































- The minute minder function sounds an alarm after a set time, to remind you to check, stir, turn or baste food, but does not switch the main oven off automatically.
- Touch the function key  repeatedly (usually one touch) until the bar above the bell symbol  starts to flash.
- While the bar is flashing, use the plus  and/or minus  keys to set the required minute minder time (up to 23 hours and 59 minutes).
- A few seconds after the last key touch, the minute minder duration time is accepted and starts counting down in the display. The bar above the bell symbol  shows solidly.
- When the minute minder duration time has elapsed, the alarm sounds. Touch the function key  to silence the alarm.
- If you wish to amend the minute minder duration time, touch the function key  repeatedly again (usually one touch) until the bar above the bell symbol  starts to flash. While the bar is flashing, use the plus  and/or minus  keys to set the updated minute minder time (up to 23 hours and 59 minutes). A few seconds after the last key touch, the updated minute minder duration time is accepted and starts counting down.
- If you wish to cancel the minute minder function, touch the function key  repeatedly again (usually one touch) until the bar above the bell symbol  starts to flash. While the bar is flashing, use the minus  key to take the minute minder time down to zero. A few seconds after the last key touch, the minute minder function is cancelled.

## USING THE TIMER FOR SEMI-AUTOMATIC COOKING

- With semi-automatic cooking, the timer will switch the main oven off after a set time, to help prevent over-cooking.
- Place the food in the main oven and select the required temperature.



- Touch the function key  repeatedly (usually two touches) until the bar above the duration time symbol  starts to flash.
- While the bar is flashing, use the plus  and/or minus  keys to set the required cooking duration time (up to 10 hours).
- A few seconds after the last key touch, the cooking duration time is accepted, and starts counting down in the background. The bar above the duration time symbol  shows solidly.
- When the cooking duration time has elapsed, the alarm sounds and the main oven heating is switched off. Turn the main oven control dial  back to the off position. Touch the function key  to silence the alarm.
- If you wish to check how much time is remaining, touch the function key  repeatedly again (usually two touches) until the bar above the duration time symbol  starts to flash. While the bar is flashing, the remaining time will be displayed.
- If you wish to amend the cooking duration time, touch the function key  repeatedly again (usually two touches) until the bar above the duration time symbol  starts to flash. While the bar is flashing, use the plus  and/or minus  keys to set the amended cooking duration time (up to 10 hours). A few seconds after the last key touch, the updated cooking duration time is accepted, and starts counting down in the background.
- If you wish to cancel the semi-automatic cooking function, touch the function key  repeatedly again (usually two touches) until the bar above the duration time symbol  starts to flash. While the bar is flashing, use the minus  key to take the cooking duration time down to zero. A few seconds after the last key touch, the semi-automatic cooking function is cancelled. Please note that the timer would not then turn the main oven off, and the main oven would need to be turned off manually by turning the main oven control dial  to the off position at the end of cooking.

## USING THE TIMER FOR FULLY-AUTOMATIC COOKING

- With fully-automatic cooking, food can be placed in the main oven earlier on, for example before going out. The timer will then switch the main oven on and off at set times so that the food is cooked ready for your return.
- The function works by setting a cooking duration time and an end time, and the timer then works out the start time. For example, if you wish the food to be ready at 18:00, and the cooking time is 1 hour, then the timer would switch the main oven on at 17:00, cook for one hour, and then switch off at 18:00.
- Place the food in the main oven.
- Touch the function key  repeatedly (usually two touches) until the bar above the duration time symbol  starts to flash.
- While the bar is flashing, use the plus  and/or minus  keys to set the required cooking duration time (up to 10 hours).
- Then touch the function key  repeatedly (usually one further touch) until the bar above the end time symbol  starts to flash.
- While the bar is flashing, use the plus  and/or minus  keys to set the required cooking end time (up to 23 hours and 59 minutes after the current time of day).
- A few seconds after the last key touch, the cooking duration time and the cooking end time are accepted, with the bars above the duration time symbol  and the end time dish symbol  showing solidly.
- Place the food in the main oven and select the temperature required.
- When the calculated start time arrives (17:00 in this example), the main oven heating is turned on and the food starts to cook for the length of the cooking duration time (1 hour in this example).
- When the cooking end time arrives (18:00 in this example), the alarm sounds and the main oven heating is switched off. Turn the main oven control dial  back to the off position. Touch the function key  to silence the alarm.
- If you wish to check the cooking duration time, touch the function key  repeatedly again (usually two touches) until the bar above the duration time symbol  starts to flash. While the bar is flashing, the cooking duration time will be displayed.
- If you wish to check the cooking end time, touch the function key  repeatedly again (usually three touches) until the bar above the end time symbol  starts to flash. While the bar is flashing, the cooking end time will be displayed.
- If you wish to amend the cooking duration time, touch the function key  repeatedly again (usually two touches) until the bar above the duration time symbol  starts to flash. While the bar is flashing, use the plus  and/or minus  keys to set the amended cooking duration time (up to 10 hours). A few seconds after the last key touch, the updated cooking duration time is accepted.
- If you wish to amend the cooking end, touch the function key  repeatedly again (usually three touches) until the bar above the end time symbol  starts to flash. While the bar is flashing, use the plus  and/or minus  keys to set the amended cooking end time (up to 23 hours and 59 minutes after the current time of day). A few seconds after the last key touch, the updated cooking end time is accepted.
- If you wish to cancel the fully-automatic cooking function, please adjust the cooking duration time to zero and the cooking end time to the current time of day.
- Firstly, touch the function key  repeatedly again (usually two touches) until the bar above the duration time symbol  starts to flash. While the bar is flashing, use the minus  key to take the cooking duration time down to zero. A few seconds after the last key touch, the bar goes out above the duration time symbol .
- Then, touch the function key  repeatedly again (usually three touches) until the bar above the end time symbol  starts to flash. While the bar is flashing, use the minus  key to take the cooking end time down to the current time of day. A few seconds after the last key touch, the bar goes out above the end time symbol .
- The fully-automatic cooking programme is now cancelled. Please note that the timer

would not then turn the main oven off, and the main oven would need to be turned off manually by turning the main oven control dial  to the off position at the end of cooking.

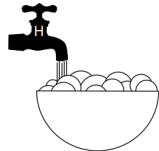
# CLEANING YOUR APPLIANCE

Cleaning: Do's	
	Use warm, soapy water
	Wipe the appliance with a damp cloth <ul style="list-style-type: none"> <li>• Clean the cloth regularly</li> </ul>
	Dry with a soft dry cloth

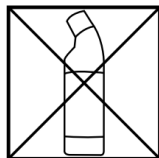
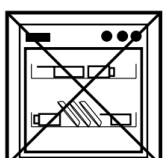
Cleaning: Don'ts	
	Don't use undiluted bleaches or Chloride products
	Don't use Wire Wool, Abrasive cleaners, Nylon pads or Steam Cleaners
	Do not wash the cast iron griddle, wok cradle, pan supports or telescopic sliders in the dishwasher



## Note

Always switch off your appliance and allow it to cool down before you clean any part of it.



## Note

Please take extra care when cleaning over the symbols on the control panel, as this can lead to them fading.



## Note

**Tips:** Some foods can mark or damage the metal or paint work e.g; Vinegar, fruit juices and salt. Always clean food spillages as soon as possible.



## Caution

It is important to clean your appliance regularly as a build up of fat can affect its performance or damage it and may invalidate your guarantee.

**Caution**

In addition to the above, do not use metal scrapers to clean the oven door glass, ceramic hob surface or any glass lids.

## CLEANING AND CARE GUIDANCE

Area of appliance / material	Cleaning guidance	Example products
Burner caps	<p>Wash with warm soapy water.</p> <p>For heavier staining, use a non-abrasive cream cleaner, following the instructions on the package.</p> <p>Please ensure that burner caps and skirts are re-positioned correctly after cleaning to avoid issues with the flame pattern and possible scorching of the hotplate.</p>	<p>Washing-up liquid.</p> <p>Non-scratch cream cleaner.</p>
Burner skirts	<p>Clean with warm soapy water and a soft sponge or soft nylon brush.</p> <p>For heavier staining, use a non-abrasive cream cleaner, following the instructions on the package.</p> <p>Make sure that there are no blockages in the burner skirt holes.</p>	<p>Washing-up liquid.</p> <p>Soft sponges, nylon washing up brush.</p> <p>Non-scratch cream cleaner.</p>
Cast iron pan supports	<p>Wash with warm soapy water.</p> <p>Dry thoroughly, do not leave wet to avoid rusting.</p> <p>For heavier staining, use a non-abrasive cream cleaner, following the instructions on the package.</p>	<p>Washing-up liquid.</p> <p>Non-scratch cream cleaner.</p>
Chrome oven shelves, grill pan trivets, and shelf guides	<p>Immerse a soft cloth in warm soapy water, wring out and wipe the shelves and shelf guides.</p> <p>For heavier soiling, soak in warm soapy water, then clean with a non-scratch sponge.</p> <p>Wave-shaped sponges can be useful for cleaning chrome shelves and grill pan trivets.</p>	<p>Washing-up liquid.</p> <p>Wave-shaped sponge.</p>

<b>Area of appliance / material</b>	<b>Cleaning guidance</b>	<b>Example products</b>
<p><b>Control knobs and bezels</b></p>	<p><b>Wipe with a damp cloth.</b></p> <p><b>On most models control knobs can be removed for more through cleaning in warm soapy water. Please refer to the section for removing and replacing the knobs, bezels and the springs that go in between them. It is a good idea to keep the user guide handy, or to take some photographs before you start removing the control knobs, so that you will be able to see which knob and bezel goes in which position when you are refitting them.</b></p> <p><b>Do not attempt to remove control knobs from pyrolytic oven models, or from models with retractable control knobs.</b></p>	<p><b>Washing-up liquid.</b></p>
<p><b>Enamelled oven cavities and grill pans</b></p>	<p><b>Wash with warm soapy water.</b></p> <p><b>For heavier soiling, use a proprietary oven cleaner spray or gel, leave to work for as long as recommended in the instructions, then wipe away and rinse.</b></p> <p><b>Do not allow oven cleaners to come into contact with stainless steel, aluminium or chrome parts, shelves, shelf supports, door seals, heating elements, or fascias with printed markings.</b></p> <p><b>Do not allow fat to build up in grill pans and do not line grill pans with aluminium foil as this presents a risk of fire.</b></p> <p><b>Grill pans can be lined with special non-stick PTFE cooking liners.</b></p> <p><b>Non-stick PTFE cooking liners can reduce soiling in ovens. Place these liners on the lower shelf, below the shelf where the food is being cooked, not on the floor of the oven cavity as this could block heat from the base element and cause damage.</b></p>	<p><b>Washing-up liquid.</b></p> <p><b>Proprietary oven cleaner.</b></p> <p><b>Non-stick PTFE cooking liners.</b></p>

<b>Area of appliance / material</b>	<b>Cleaning guidance</b>	<b>Example products</b>
<b>Glass control panel</b>	<p>Immerse a non-abrasive cloth in warmy soapy water, wring out well and clean the glass control panel.</p> <p>Polish with a soft microfibre cloth.</p>	<p>Washing-up liquid.</p> <p>Microfibre cloths.</p>
<b>Glass door parts</b>	<p>Wash with warm soapy water.</p> <p>To remove grease from inner glass panels, use a proprietary oven cleaner spray or gel, leave to work for as long as recommended in the instructions, then wipe away and rinse.</p> <p>Polish with a soft microfibre cloth.</p> <p>Do not allow oven cleaners to come into contact with stainless steel, aluminium or chrome parts, shelves, shelf supports, door seals, heating elements, or fascias with printed markings.</p>	<p>Washing-up liquid.</p> <p>Proprietary oven cleaner.</p> <p>Microfibre cloths.</p>
<b>Grill compartment</b>	<p>It is a good idea to leave the grill element on for a few minutes after finishing cooking to burn off any grease on the heating element. Do not leave a grill-pan containing grease under the grill element during this procedure.</p> <p>Once the grill compartment has cooled down, it can be wiped down with a damp wrung-out cloth which has been soaked in warm soapy water.</p> <p>Wave-shaped sponges can be useful for cleaning chrome shelves, grill pan trivets, and for cleaning the roof of the grill cavity, getting in between the grill element.</p>	<p>Washing-up liquid.</p> <p>Wave-shaped sponges.</p>
<b>Rubber door seals</b>	<p>Clean with warm soapy water.</p> <p>Do not attempt to clean fibreglass door seals on pyrolytic ovens.</p>	<p>Washing-up liquid.</p>

<b>Area of appliance / material</b>	<b>Cleaning guidance</b>	<b>Example products</b>
<p><b>Stainless steel - gas hotplates</b></p>	<p><b>On gas hobs, please ensure that the burner caps and burner skirts are correctly assembled and sitting level, as otherwise the flames may be forced out at a strange angle, causing scorching to the stainless steel hotplate.</b></p> <p><b>Clean stainless steel with warm soapy water and a soft sponge.</b></p> <p><b>For more stubborn stains, use a non-scratch stainless steel cream cleaner applied with kitchen paper.</b></p> <p><b>Do not scrub fascias / control panels as the markings could start to wear away.</b></p> <p><b>Rinse with warm water and a soft cloth.</b></p> <p><b>Polish dry with a microfibre cloth.</b></p>	<p><b>Washing-up liquid.</b></p> <p><b>Stainless steel cream cleaner.</b></p> <p><b>Microfibre cloths.</b></p>
<p><b>Steel - gas hotplates, fascia control panels</b></p>	<p><b>On gas hobs, please ensure that the burner caps and burner skirts are correctly assembled and sitting level, as otherwise the flames may be forced out at a strange angle, causing scorching to the hotplate.</b></p> <p><b>Clean steel parts with warm soapy water and a soft sponge.</b></p> <p><b>Do not scrub fascias / control panels as the markings could start to wear away.</b></p> <p><b>Rinse with warm water and a soft cloth.</b></p> <p><b>Polish dry with a microfibre cloth.</b></p>	<p><b>Washing-up liquid.</b></p> <p><b>Microfibre cloths.</b></p>

# APPLIANCE MAINTENANCE

## CHANGING THE LIGHTBULBS

The large oven compartment has two lamps.

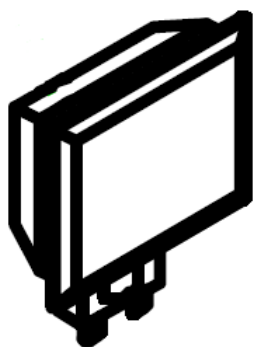

On the left-hand side of the oven compartment, the light-bulb is behind a flat glass cover.

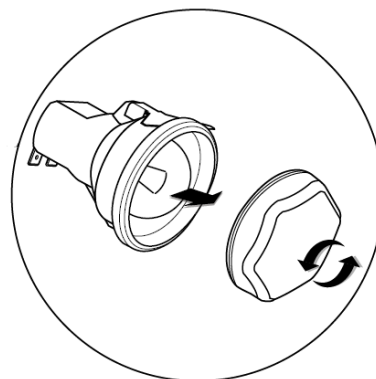

On the roof of the oven compartment, the light-bulb is behind a circular glass cover.

Switch the cooker off at the wall.

If replacing the left-hand-side bulb, remove the oven shelves, grill pans and any other trays as appropriate. Please also remove the left-hand shelf guide.



**Tip**

It's a good idea to place a towel on the floor of the oven cavity to help prevent damage to the glass covers if they are dropped.

For the left-hand-side lamp, use a flat-bladed screwdriver to gently prise the flat glass cover open and off.

Pull out the old bulb and replace it with a new one. Handle the new bulb with a piece of kitchen paper as skin oils can damage halogen bulbs.

For the left-hand-side lamp, clip the flat glass cover back into position.

Replace the shelf guide, shelves and grill pans.

Switch the cooker back on at the wall and set the time of day on the timer.

Switch the cooker off at the wall.

If replacing the roof bulb, remove any grill pans and shelves which may be preventing access to that area.



**Tip**

It's a good idea to place a towel on the floor of the oven cavity to help prevent damage to the glass covers if they are dropped.

For the roof lamp, unscrew the circular glass cover by turning anticlockwise.

Pull out the old bulb and replace it with a new one. Handle the new bulb with a piece of kitchen paper as skin oils can damage halogen bulbs.

For the roof lamp, screw the circular glass cover back into position by turning it clockwise.

Replace any grill pans and shelves which had been removed.

Switch the cooker back on at the wall and set the time of day on the timer.

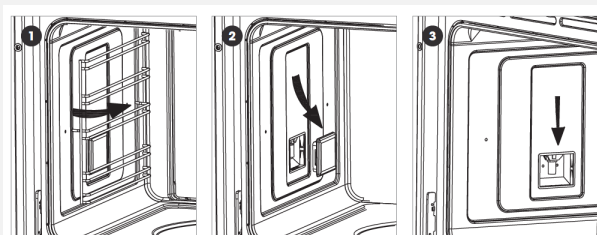

**Warning**

Always switch off the power before you change the light bulb.



### Caution

**Do not use the oven with the glass lamp covers missing or if they are damaged.**



### Note

**Not all appliances have the same number and type of bulbs. Before you replace your bulb, check to see what type you have. Usually a 25 watt G9 halogen capsule bulb - part number 082650920.**

**Please remember that bulbs are not covered by the manufacturer's warranty.**

## OVEN SHELVES

The oven shelves use anti-tip notches to prevent them being accidentally pulled out fully with hot food and cookware on them, to help prevent accidents.

### Shelves With Anti-Tip Notches.

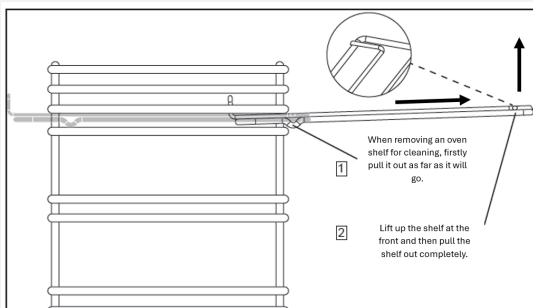

**To remove the shelves fully, for cleaning or to reposition them, pull the shelf out as far as it will go, then lift upwards at the front to pull out fully.**

## Shelves.

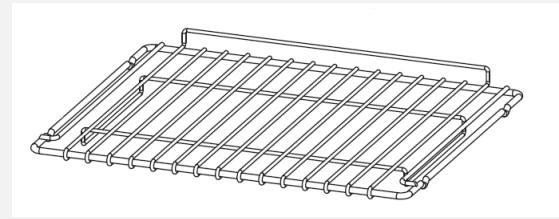

**When inserting the shelves into the shelf guides, ensure that the upstand piece is at the back of the shelf and is pointing upwards. (Not all shelf types have an upstand).**

**The anti-tip notches should always be pointing downwards, and should be towards the back of the shelf.**

## Shelf Guides.

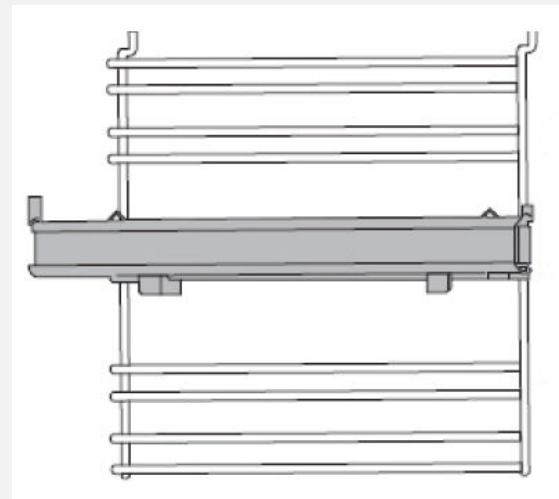

### Caution

**Each shelf guide position consists of an upper and a lower wire. Please insert the shelf between the two wires, and not sitting on top of the upper wire.**

## REMOVING AND REPLACING SHELF GUIDES

**The shelf guides have lugs which attach into holes on the side of the oven cavity.**

**To remove the shelf guides for cleaning, firstly please remove the shelves and/or grill pans as appropriate.**

Pull firmly on the shelf guide at the front, closest to you, and then at the rear, closest to the back of the oven. Keep pulling alternately at the front and the rear to 'walk' the shelf guide out. The shelf guide may be tight when removed for the first time.

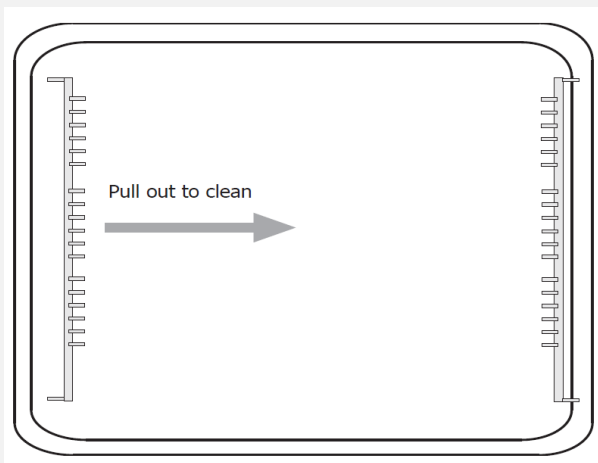
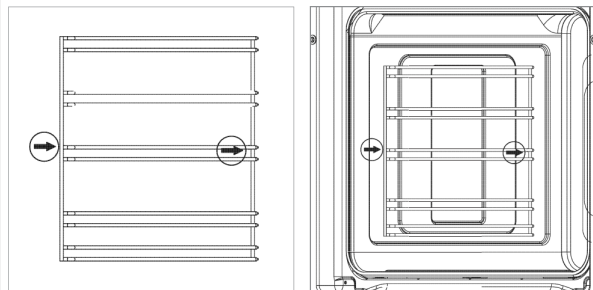

The shelf guide can then be pulled away from the side of the oven cavity. The shelf guide lugs will come out of the holes in the side of the cavity.

The shelf guide is replaced in the opposite manner. Insert the lugs into the holes on the side of the oven cavity. Then, push firmly at the front of the guide and then at the rear of the guide until it snaps into position.

## REMOVING AND RE-FITTING CONTROL DIALS, SPRINGS AND BEZELS

The control dial assembly consists of the dial at the front, a bezel with markings around the dial, and a spring between the dial and the bezel.

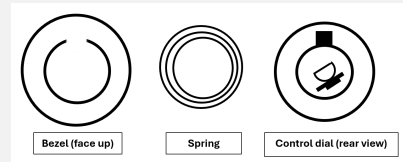

For cleaning, the bezels can be carefully slid forward to allow easy cleaning of the fascia control panel behind with a cloth.

The bezels will spring back into position when you let go.

For more thorough cleaning, the dials, bezels and springs can be removed as follows.

Firstly, please take a moment to note the positions of the different types of bezels on the cooker, take some photographs or have the appliance user guide handy. This will help you to replace the controls in the correct positions after cleaning.

Ensure that all of the control dials are in the 'off' position, and that the cooker is turned off at the wall.

Push the control dial in towards the bezel.

Then, holding the dial and bezel together, pull them both towards you and off the cooker spindle.

Be careful not to lose the spring, or the small silver clip which is inside the control dial shaft.

To re-fit the control dials, bezels and springs, please follow these steps:

Place the bezel face up on a flat surface. Position the cutout notch in the inner circle of the bezel at the top.

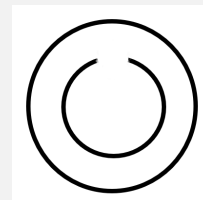

Place the spring over the hole in the middle of the bezel.

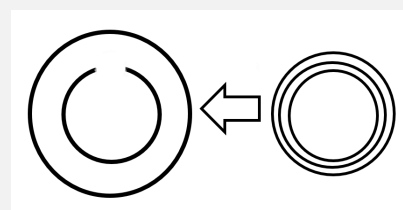

Place the control dial on top of the bezel, ensuring that the shaft on the back of the control dial is located through the middle of the spring.

Line up the square-shaped lug on the back of the control dial with the square-shaped cutout on the bezel.

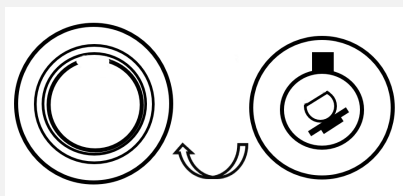

While keeping the control dial and bezel held together firmly, align the flat side of the D-shaped hole on the back of the control dial with the flat side of the D-shaped spindle on the cooker control panel.

Still keeping them held together firmly, push the control dial and bezel assembly onto the spindle as far as it will go.

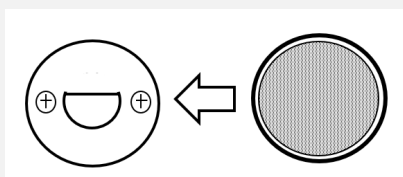

The control dial can now be used as normal.

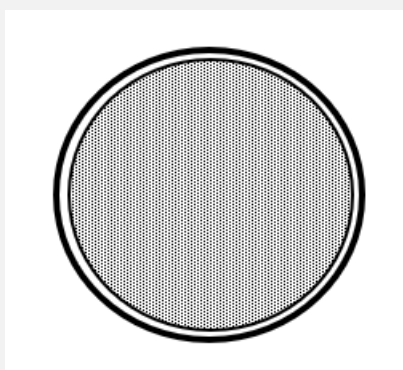

Please follow this link for a video on fitting the control dials, bezels and springs:



<https://www.youtube.com/embed/O06nvrJKa7A>

<https://youtu.be/O06nvrJKa7A>

## REMOVING THE INNER GLASS PANELS FOR CLEANING

The inner and middle glass door panels can be removed for cleaning.



### Caution

Switch the appliance off at the wall and allow it to cool down before commencing cleaning.

It is recommended to wear work gloves during this procedure.



### Notice

Please read these instructions fully before removing any door panels, and ensure that you are comfortable with the procedure before proceeding.

Please note that if a service engineer was requested to remove or refit door panels, this would be arranged on a chargeable basis, even if the cooker is still within the manufacturer's warranty period.

The inner glass panel can now be slid forward and out for cleaning. The inner glass panel has a black border to distinguish it from the middle glass, which is clear.

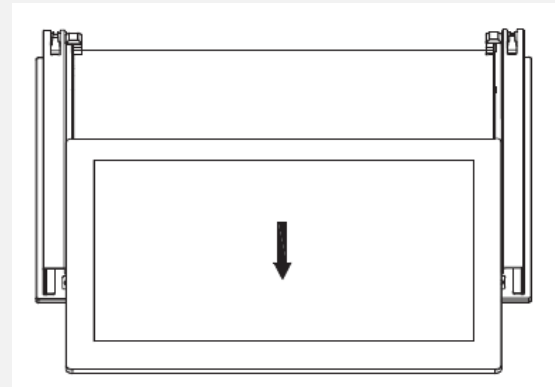

The middle glass panel can also be slid forward and out for cleaning.

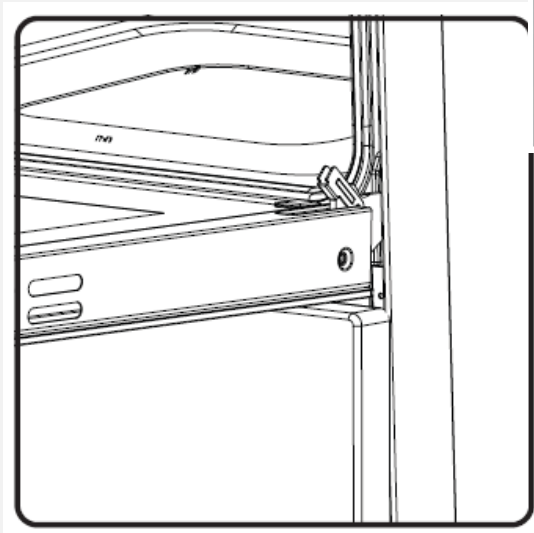

Open the oven door fully to a 90° angle.

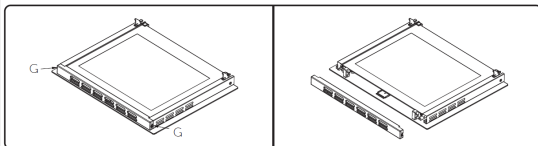

Locate the screws (key G) on either end of the metal retaining strip along the top of the door assembly.

Remove these screws with a cross-head screwdriver, being careful not to misplace them.

Pull the metal retaining strip forwards and off the door assembly.

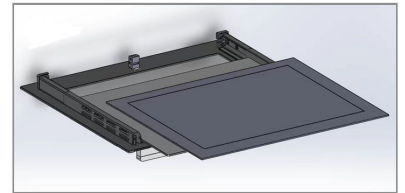
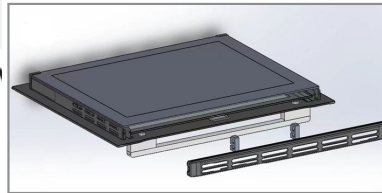

### Caution

Caution - when the weight of the inner and middle glass panels is removed from the door assembly, the door assembly may spring up.

It is advisable to have a second person available to hold the door assembly down by gently holding the door handle while you are removing and re-inserting the inner and middle glass panels.

When replacing the clear middle glass panel, slide it carefully in so that it slots into the grooves in the two buffers at the back of the door assembly.

When replacing the inner glass panel, ensure that the smooth shiny side of the black border

is facing upwards towards the heat of the oven. The writing 'Warning: Grill with the door closed. Never lay pans on the oven bottom.' must face upwards and be at the back of the glass, closest to the oven. Slide the inner glass panel in carefully so that it slots into the two metal clips at the bottom-left and bottom-right corners of the door assembly.

After sliding the middle and inner glass panels back into position, place the metal retaining strip back on to the top of the door assembly, ensuring that the ventilation holes are facing towards the oven. Secure the retaining strip in place with the screws.



### **Caution**

**Do not use the oven with the middle or inner glass panels missing as the outer door could get very hot.**

**The door assembly is heavy. Do not attempt to remove the entire door assembly from the body of the cooker.**

**In order to reduce the risk of breakage, always handle glass panels carefully, cover surfaces with towels when laying the glass panels down, and never use abrasive cleaning materials or scourers.**



## FAQ's

Please refer to these frequently asked questions about your appliance as they may help to resolve any minor issues.

Should any issue persist after following this advice, please contact the service office for further assistance.

<p><b>Can I remove the inner glass on the doors for cleaning?</b></p>	<p>The inner glass panels are removable for cleaning, however this does involve unscrewing the retaining metal strip from the top of the door assembly to gain access to the inner door panels.</p>
<p><b>There's been a power failure and the cooker won't work- what should I do?</b></p>	<p>Switch off the electricity supply to the cooker at the wall switch.</p> <p>When the power supply is restored switch the electricity supply back on at the wall and re-set the timer clock to the correct time of day.</p>
<p><b>Why is there some warm air coming out of the sides of the doors?</b></p>	<p>This is normal. The doors have some side vents which allows a small amount of this heat to be expelled at the door sides to help keep the door surfaces cool.</p>
<p><b>How do I attach the grill-pan handle to the grill-pans?</b></p>	<p>Attach the handle to the grill-pans making sure the prongs are at the top and the wider support piece sits underneath the grill-pans.</p> <p>When using both grill-pans, position the grill-pan handle centrally so that it can be used to withdraw both of the grill-pans together.</p>
<p><b>Why can I not remove the shelves completely for cleaning?</b></p>	<p>The shelves have 'anti-tip notches' which prevent the shelves being accidentally pulled out completely with cookware on the shelf, to help prevent accidents.</p> <p>To remove the shelves fully for cleaning, pull the shelf out, then lift upwards at the front to pull out fully.</p>

<p><b>I am having difficulty lighting the hob burners, or with the hob burners cutting out.</b></p>	<p><b>Please ensure that there is power to the cooker, that the timer display is lit up and that the gas supply to the appliance or property has not been switched off or interrupted.</b></p> <p><b>Please ensure that that the burner caps and skirts are clean, free of blockages and have been assembled correctly.</b></p> <p><b>Keep the burner control knob held in while turning it - this will activate the clicking of the ignition system.</b></p> <p><b>If the burner lights, keep the control knob held in for 10-15 seconds after the flame has lit to allow time for the flame safety system to warm up; otherwise the flame will go out when the control knob is released.</b></p> <p><b>If the burner does not light, return the control knob to the off position.</b></p> <p><b>Wait 1 minute for any unburnt gas to dissipate before trying to ignite again.</b></p> <p><b>Should the issue persist, please turn the hob controls to the off position and contact the service office as the appliance may require servicing.</b></p>
<p><b>There is constant clicking from the hob ignition.</b></p>	<p><b>The ignition spark plugs may have become wet from recent cleaning or a pan boiling over.</b></p> <p><b>Do not touch the spark plugs while they are clicking and sparking.</b></p> <p><b>Switch the cooker off at the wall to stop the clicking and allow 24 hours for the hob area to dry.</b></p> <p><b>The hob burners can be lit with a gas lighter or taper if the hob needs to be used during this time.</b></p> <p><b>Once the hob has dried out, switch the cooker back on at the wall.</b></p> <p><b>Should the issue persist, please contact the service office as the appliance may require servicing.</b></p>



<p><b>Why is the main oven not working?</b></p>	<p>Please check that there is power to the cooker and the timer display is lit up.</p> <p>Please ensure that the time of day has been set on the timer.</p> <p>Please ensure that there are no bars flashing on the timer display. If they are flashing, please press the middle function key  to return the timer to manual mode.</p> <p>Ensure that both a cooking function and a cooking temperature have been selected on the control dials.</p> <p>Ensure that the oven door is closed firmly - the oven will not work with the door open.</p>
<p><b>I have found two hooks inside the oven with the shelves - what are they for?</b></p>	<p>These new models have two stability chains fitted to the back of the cooker.</p> <p>The hooks are provided to be drilled into the wall behind the cooker to attach the stability chains to.</p> <p>If you already had hooks in the wall from your previous cooker, the installer may have re-used those hooks which is why the new ones are still in the packaging.</p> <p>If in doubt, please consult your installer.</p>
<p><b>The main oven does not seem to return to manual mode after I have used automatic cooking.</b></p>	<p>When the oven heating switches off at the end of semi-automatic cooking or fully-automatic cooking, turn the main oven function and temperature control dials back to the off position.</p> <p>Then press the middle function key  on the timer to silence the alarm and return the timer to manual mode.</p>
<p><b>The grill seems to be taking a long time to cook.</b></p>	<p>Please ensure that the door is kept closed during grilling to keep the heat in for better grilling results and energy-efficiency.</p> <p>For best results , please pre-heat the grill for 3-5 minutes before use, and position the food on the grill pan trivet using a suitable shelf position which brings the food close to the grill element without the food touching the grill element.</p>
<p><b>The oven lamps are not working.</b></p>	<p>Please refer to the section on <a href="#">changing the lightbulb</a>. [35]</p>

<p><b>The oven seems to be overheating.</b></p>	<p>Please ensure that the oven control knob has been turned to the required temperature.</p> <p>When using the conventional oven setting, place the food on the middle shelf position. The oven will be hotter at the top.</p> <p>When using the fanned oven setting, please remember that the temperature will need to be reduced by about 20°C and the duration reduced a little compared to conventional oven cooking instructions.</p>
<p><b>The oven seems to be under-heating.</b></p>	<p>Please ensure that the oven control knob has been turned to the required temperature.</p> <p>When using the conventional oven setting, place the food on the middle shelf position. The oven will be cooler at the bottom.</p> <p>When using the conventional oven setting, pre-heat the oven for 10-15 minutes prior to use.</p> <p>Check that the door is closing and sealing well, and that the door seal is in good condition.</p> <p>Ensure that any additional tins and trays which are not being used are removed from the oven before cooking.</p> <p>Use good quality bakeware with a dull, matt finish; avoid bakeware with a shiny silver finish.</p>
<p><b>There is a strange smell / a little smoke produced when using the oven for the first time.</b></p>	<p>This is normal. The oils used to protect the oven cavity during storage of the appliance are being burnt off.</p> <p>Heat the oven empty for around 30 minutes at around 180°C to allow the smell / smoke to dissipate. Open the kitchen window(s) during this procedure.</p>

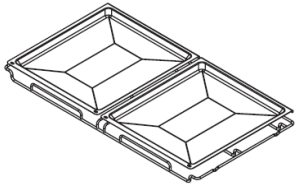

For more useful information and FAQs, please visit our online FAQ section at: [Range Cooker FAQs](#)

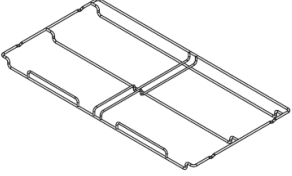
# KEY PARTS AND OPTIONAL ACCESSORIES

Item	Quantity supplied with cooker	Part Number	Notes
 <p data-bbox="209 925 328 954"><b>Grill-pan</b></p>	2	30401000025	<p data-bbox="1067 656 1310 763">Can also be used as baking trays or roasting tins.</p> <p data-bbox="1067 801 1374 1021">The grill-pans are inserted sideways into the grill-pan holder, before the holder is inserted into the shelf guides in the oven.</p> <p data-bbox="1067 1059 1378 1205">Ensure that the lip of the grill-pan is hooked over the rear wire of the holder for stability.</p>

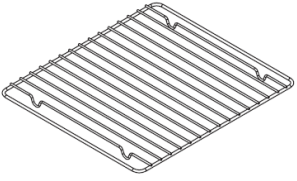
Item	Quantity supplied with cooker	Part Number	Notes
 <p data-bbox="209 640 424 674"><b>Grill-pan holder</b></p>	1	30400100052	<p data-bbox="1067 378 1378 488"><b>Place the grill-pans sideways into the grill-pan holder.</b></p> <p data-bbox="1067 524 1378 674"><b>Ensure that the lip of the grill-pan is hooked over the rear wire of the holder for stability.</b></p> <div data-bbox="1070 741 1385 1756" style="background-color: #e0e0e0; padding: 10px;"> <p data-bbox="1110 792 1177 846"></p> <p data-bbox="1209 792 1358 1704"><b>Warning</b> Always use oven gloves and the grill-pan handle, and exercise caution when removing the grill-pan holder and grill-pans from a hot oven.</p> </div>

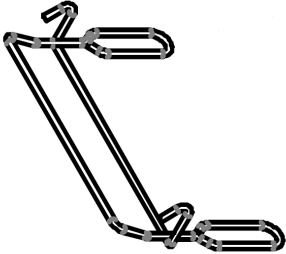
<b>Item</b>	<b>Quantity supplied with cooker</b>	<b>Part Number</b>	<b>Notes</b>
 <p data-bbox="209 645 411 678"><b>Grill-pan trivet</b></p>	2	30304200053	Place the trivets inside the grill-pans to support the food when grilling.

Item	Quantity supplied with cooker	Part Number	Notes
 <p data-bbox="209 714 427 745">Grill-pan handle</p>	1	30400800001	<p data-bbox="1067 378 1350 521">Used when inserting and withdrawing the grill-pans on the holder.</p> <p data-bbox="1067 562 1358 705">Position the grill-pan handle centrally to securely attach it to both grill-pans.</p> <p data-bbox="1067 745 1377 965">The wide area of the grill-pan handle is placed underneath the grill-pans, while the prongs attach to the top of the grill-pans.</p> <div data-bbox="1070 1039 1386 2040" style="background-color: #e0e0e0; padding: 10px;"> <p data-bbox="1110 1088 1177 1144"></p> <p data-bbox="1209 1088 1358 2040"><b>Warning</b> Do not leave the grill-pan handle attached to the grill-pans during grilling, as the handle could get very hot and the oven door needs to be fully closed</p> </div>

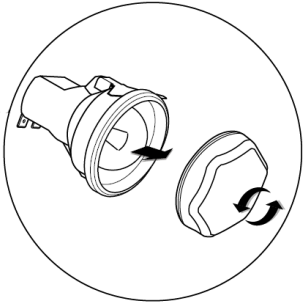
Item	Quantity supplied with cooker	Part Number	Notes
			<p><b>when grilling.</b></p> <p><b>Do not attempt to carry hot grill-pans using the grill-pan handle - risk of burns, scalding and injury.</b></p>
 <p><b>Lamp bulbs</b></p>	2	082650920	<p>Type - 25 watt G9 halogen capsule bulb.</p> <p>Please note that replacement bulbs are not covered under the manufacturer's warranty.</p>
LPG Conversion Kit	Optional extra	<p>40499800275 for UK and Ireland</p> <p>40499800276 for continental Europe</p>	<p>Can be purchased as an optional extra.</p> <p>For converting the gas hob from natural gas to run on LPG.</p>

Item	Quantity supplied with cooker	Part Number	Notes
 <p data-bbox="209 645 280 674">Shelf</p>	2	30400100042	<p data-bbox="1067 378 1366 483">There are 5 shelf positions for the oven shelves.</p> <p data-bbox="1067 524 1374 667">Insert the shelf with the anti-tip notches at the back and facing downwards.</p> <div data-bbox="1070 741 1385 2040" style="background-color: #e0e0e0; padding: 10px;"> <p data-bbox="1110 790 1177 846"></p> <p data-bbox="1209 790 1358 824"><b>Warning</b></p> <p data-bbox="1222 835 1358 1630"><b>Insert the shelf between the two wires of the shelf guide position, not on top of the upper wire - danger of scalding or injury.</b></p> <p data-bbox="1222 1671 1358 2040"><b>Do not attempt to place a shelf on top of the shelf guides as the shelf</b></p> </div>

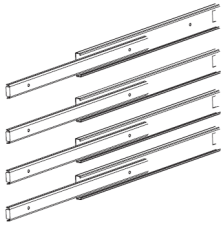
Item	Quantity supplied with cooker	Part Number	Notes
			<p><b>will not be held in a stable position and could tip out - danger of scalding or injury.</b></p> <p>When removing a shelf for cleaning, wait for the shelf to cool, then pull it outwards and lift it upwards to remove it completely.</p> <p>The useable shelf area is approximately 761mm wide by 390mm deep.</p>
 <p><b>Telescopic Sliders</b></p>	<p><b>Optional extra</b></p>	<p><b>Left hand side slider: 1 x 094109802</b></p> <p><b>Right hand side slider: 1 x 094109803</b></p> <p><b>You need 1 x 094109802 and 1 x 094109803 to make a pair.</b></p>	<p><b>Can be purchased as an optional extra.</b></p> <p><b>Used in the oven compartment to support a shelf or grill-pan holder.</b></p>

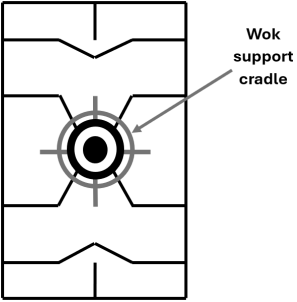
Item	Quantity supplied with cooker	Part Number	Notes
 <p data-bbox="209 741 485 775"><b>Wok Support Cradle</b></p>	1	30402600080	Sits over the wok pan support to accommodate round-bottomed woks.

## FITTING THE DECORATIVE COVER PLINTH

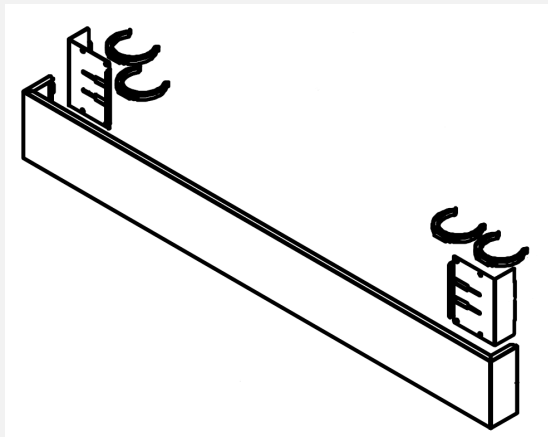

Once the cooker has been moved to its final location, levelled and connected, clip the decorative cover plinth onto the front legs, if desired.



### Notice

Please note that the legs need to be extended to a height of at least 110mm in order to fit the decorative cover plinth.

# LOCATING THE MODEL AND SERIAL NUMBERS

- Please open the oven door and locate the data badge on the left-hand side of the frame.
- Please quote the model number and serial number should you ever require an engineer service visit or need to order spare parts.
- The model number (also known as the SKU number or Model description) is 9 digits long, beginning with 44...
- The serial number is printed as a string of 17 digits - the first 8 digits are the serial number and the remaining 9 digits are the model number.

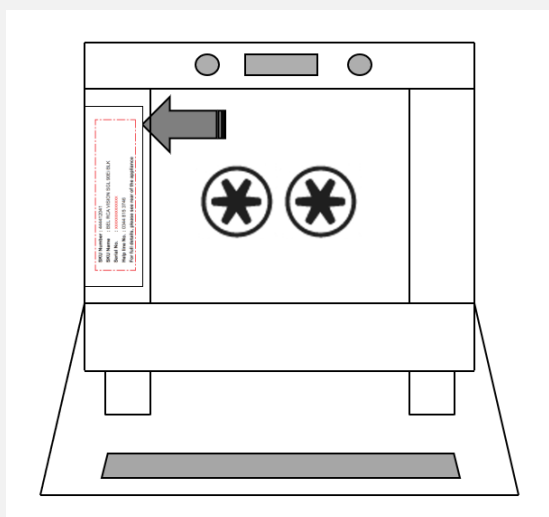

## Tip

It is a good idea to take a photo of the data badge or to make a written note of the model number and serial number on your quick start guide.

# TECHNICAL DATA



### Important

This cooker is configured for use with natural gas, and is suitable for conversion to LPG.



### Important

If the cooker is required to use LPG, a conversion kit is available. Please contact the Customer Care Centre for more information.

### LPG Conversion Kit Part Numbers

Country of destination	LPG Conversion Kit Part Number
GB and IE	40499800275

Country of destination	LPG Conversion Kit Part Number
BE, DE, NL, PL, SE	40499800276

Before installation check that the cooker is suitable for the local gas supply.

To do this check the gas type on the carton sticker or on the data plate on the rear of the cooker.

The following shows the supply and operating pressures for various gas supplies.

**Operating pressure at appliance test point (GB and IE):**

- 20mbar (Natural gas);
- 30mbar (LPG)

### Countries Of Destination And Gas Categories

Country of destination	Appliance Category
Belgium (BE )	I12E+3+ (20/25, 28-30/37)
Germany (DE)	I12E3B/P (20, 50) I12ELL3B/P (20, 50)
UK (GB)	I12H3+ (20,28-30/37)
Ireland (IE)	I12H3+ (20,28-30/37)
Netherlands (NL)	I12EK3B/P (20/25, 30)
Poland (PL)	I12E3B/P (20,37)
Sweden (SE)	I12H3B/P (20,30)

### Hotplate Burners Nominal Heat Input

	<b>Auxiliary NG</b>	<b>Auxiliary LPG</b>	<b>Semi-rapid NG</b>	<b>Semi-rapid LPG</b>
<b>kW</b>	1.0	1.0	1.75	1.75
<b>G30 Butane (g/h)</b>	N/A	72.7	N/A	127.2
<b>G31 Propane (g/h)</b>	N/A	71.5	N/A	125.1

### Hotplate Burners Nominal Heat Input (Continued)

	<b>Rapid NG</b>	<b>Rapid LPG</b>	<b>Wok NG</b>	<b>Wok LPG</b>
<b>kW</b>	3.0	3.0	3.8	3.8
<b>G30 Butane (g/h)</b>	N/A	218.1	N/A	276.3
<b>G31 Propane (g/h)</b>	N/A	214.4	N/A	271.6

### Hotplate Burner Injector Specifications (Ø)

<b>Country of destination</b>	<b>Auxiliary NG 1.0 kW</b>	<b>Auxiliary LPG 1.0 kW</b>	<b>Semi-rapid NG 1.75 kW</b>	<b>Semi-rapid LPG 1.75 kW</b>
<b>Belgium (BE)</b>	0.72	0.5	0.97	0.65
<b>Germany (DE)</b>	0.72	0.43	0.97	0.58
<b>UK (GB)</b>	0.72	0.5	0.97	0.65
<b>Ireland (IE)</b>	0.72	0.5	0.97	0.65
<b>Netherlands (NL)</b>	0.72	0.5	0.97	0.65
<b>Poland (PL)</b>	0.72	0.5	0.97	0.65
<b>Sweden (SE)</b>	0.72	0.5	0.97	0.65

### Hotplate Burner Injector Specifications (Ø) (Continued)

<b>Country of destination</b>	<b>Rapid NG 3.0 kW</b>	<b>Rapid LPG 3.0 kW</b>	<b>Wok NG 3.8 kW</b>	<b>Wok LPG 3.8 kW</b>
<b>Belgium (BE)</b>	1.18	0.85	1.49	0.98
<b>Germany (DE)</b>	1.18	0.75	1.49	0.77

Country of destination	Rapid NG	Rapid LPG	Wok NG	Wok LPG
	3.0 kW	3.0 kW	3.8 kW	3.8 kW
UK (GB)	1.18	0.85	1.49	0.98
Ireland (IE)	1.18	0.85	1.49	0.98
Netherlands (NL)	1.18	0.85	1.49	0.98
Poland (PL)	1.18	0.81	1.49	0.93
Sweden (SE)	1.18	0.85	1.49	0.98



**Warning**  
**This cooker must be earthed.**

<b>Data badge</b>	<p>Please open the oven door and locate the data badge on the left-hand side of the frame.</p> <p>The main data badge is on the rear of the appliance.</p>
<b>Appliance class</b>	Class 1 - freestanding cooker
<b>Electrical supply</b>	220 - 240V ~1N ~ 50 Hz
<b>Load (W)</b>	2475 W - 2945 W
<b>Max. heat input</b>	$\sum Q_n$ 11.3kW
<b>Type of gas</b>	<p>This cooker is supplied for use with Natural Gas and can be converted to LPG.</p> <p>Please see data badge for your specified gas type. Never attempt to convert an appliance unless the data badge states you can.</p>
<b>Burner Aeration</b>	Fixed
<b>Grill</b>	Electric
<b>Hob</b>	Burners have burner skirts and caps which are removable for cleaning. Concealed electrodes to each burner.

# ENERGY DATA TABLE

Regulation (EU) 66/2014:

Model Identification: BEL RCA VS SGL 90 DF	
Brand:	Belling
Size:	90cm

## Energy Efficiency For Oven

Oven	Cavity 1
Mass of the appliance (M): 40kg	
Number of cavities: 1	
Type of oven:	Electric oven
Heat source per cavity:	Electricity
Volume per cavity (V):	133 Litres
Energy consumption (electricity consumed) per cycle in conventional mode ( $EC_{\text{electric cavity}}$ ):	1,20 kWh
Energy consumption (electricity consumed) per cycle in fan-forced convection mode ( $EC_{\text{electric cavity}}$ ):	1,03 kWh
Energy efficiency index per cavity ( $EEI_{\text{cavity}}$ ):	92,8
Energy efficiency class:	A

## Energy Efficiency For Hob

Hob	
Type of hob:	Gas
Number of hob burners:	5
Heating technology:	Gas burners

Gas hob burner:	Location:	Size:	Energy efficiency per gas burner ( $EE_{\text{gas burner}}$ ):
Burner 1	Front-left	Rapid	EEI 58.61%
Burner 2	Back-left	Semi-rapid (Left)	EEI 59.3%
Burner 3	Centre	Wok	EEI 53.33%
Burner 4	Front-right	Auxiliary	EEI N/A (auxiliary)

Burner 5	Back-right	Semi-rapid (Right)	EI 61.3%
----------	------------	--------------------	----------

Energy efficiency for the gas hob (EE <sub>gas hob</sub> ):	EI 58.09%
---	-----------

*Energy consumption measured in accordance with EN 60350-1 and EN 30-2-1*

## ENERGY SAVING TIPS FOR HOBS



### Tip

**Use pans with flat bases.**

**Use pans which are suitably-sized for the size of the cooking zone.**

**Use pans with lids.**

**Minimise the amount of liquid or fat when cooking.**

**When liquid starts boiling, reduce the power level to a simmer.**

**Using a pan with a base diameter a little larger than the diameter of the cooking zone gives the most energy-efficient cooking results.**

## ENERGY SAVING TIPS FOR OVENS



### Tip

**Cook separate meals together, if possible.**

**Keep the pre-heating time as short as possible.**

**Do not elongate the cooking time.**

**Do not forget to turn the oven off at the end of cooking.**

**Do not open the oven door during the cooking process.**

**If the oven has a programmable timer, use the timer to switch the oven heating off at the end of cooking.**

**If cooking for longer periods, turning the oven heating off 10 minutes before the end of cooking can save energy by using the residual heat to finish the cooking process. Always ensure that food is thoroughly cooked through.**

# SERVICE CONTACT DETAILS

<b>Ireland</b>	<b>Tel: +353 (0) 1 8428222</b> <b>Service e-mail: <a href="mailto:serviceireland@glendimplex.com">serviceireland@glendimplex.com</a></b> <b>Spare parts enquiries e-mail: <a href="mailto:sparesireland@glendimplex.com">sparesireland@glendimplex.com</a></b> <b><a href="http://www.glendimplexireland.com">www.glendimplexireland.com</a></b> <b>Glen Dimplex Ireland UC, Airport Road, Cloghran, Co. Dublin, K67 DT89</b>
<b>United Kingdom</b>	<b>Stoves Service Tel: +44 (0) 344 815 3740</b> <b><a href="http://www.stoves.co.uk">www.stoves.co.uk</a></b> <b>Belling Service Tel: +44 (0) 344 815 3746</b> <b><a href="http://www.belling.co.uk">www.belling.co.uk</a></b> <b>Glen Dimplex Home Appliances, Element, Temple Court, Risley, Warrington, WA3 6GD</b>

**This page is intentionally left blank.**

**This page is intentionally left blank.**

**This page is intentionally left blank.**

**This document relates to these models:**

<b>Model Number:</b>	<b>Model Description:</b>
<b>444412039</b>	<b>BEL RCA VISION SGL 90DF BLK</b>
<b>444412040</b>	<b>BEL RCA VISION SGL 90DF BSS</b>

**Glen Dimplex Home Appliances, Element, Temple Court, Risley,  
Warrington, WA3 6GD.**

**0344 815 3746**

**[www.belling.co.uk](http://www.belling.co.uk)**

**GDHA Part Number: UG RG BEL VS 90S DF UK V2**

