

110cm Gas Range Cooker

Gas hob with Gas ovens & grill

INSTALLATION AND USER INSTRUCTIONS

Model: CE 1100G

**You must read these instructions prior to using the
appliance and retain them for future reference.**



If you smell gas:

Do not try to light any appliance. Do not touch any electrical switch.

Call the Gas Emergency Helpline at TRANSCO on: **0800 111999**

In case of difficulty within the UK and Northern Ireland, please call
Belling Customer Care Centre Helpline on

0870 444 9939

When you dial this number you will hear a recorded message and be given a number of options. This indicates that your call has been accepted and is being held in a queue. Calls are answered in strict rotation as our Customer Care Representatives become available.

Opening Hours for Customer Care

Monday to Friday	8am - 8pm
Saturday	8.30am - 6pm
Sunday	10am - 4pm

Please have to hand you Model Number and Serial Number to hand when calling
as this will help process your call quicker.

Contents

User's Section	2 - 15
Introduction	2
Storage Compartment	5
Be Safe - Not Sorry	6
Using the Minute Minder	7
Using the Hob	8
Using the Grill	10
Using the Ovens	13
Cleaning	29
 Installation Instructions	 22 - 28
 Technical Data	 29
 Belling Customer Care.	 30

Please keep this handbook for future reference, or for anyone else who may use the appliance.

Introduction

Thank you for choosing a British built appliance by Belling.

We hope that the following information will help you to familiarise yourself with the features of the appliance, and to use it successfully and safely.

Our policy is one of constant development and improvement. Strict accuracy of illustrations and specifications is not guaranteed. Modification to design and materials may be necessary subsequent to publication.

This appliance must be installed in accordance with the regulations in force, and only in a well ventilated space. Read the instructions before installing or using this appliance.

Your 1st Year Guarantee

To fulfil the conditions of your guarantee, this appliance must be correctly installed and operated, in accordance with these instructions, and only be used for normal domestic purposes. Please refer to your Guarantee Card for further details.

Please note that the guarantee, and Service availability, only apply to the UK.

Your new appliance is designed to be installed free-standing or flush to base units.

Before using the appliance for the first time, remove any protective polythene film and wash the oven shelves and furniture in hot soapy water, to remove their protective coating of oil. Even so, when you first turn on the oven or grill you may notice a smell and some smoke.

Ventilation

The use of a gas cooking appliance results in the production of heat and moisture in the room in which it is installed. Ensure that the kitchen is well ventilated: keep natural ventilation holes open or install a mechanical ventilation device (mechanical extractor hood). Prolonged intensive use of the appliance may call for additional ventilation, for example, opening of a window, or more effective ventilation, for example increasing the level of mechanical ventilation where present.

Introduction

Moving the cooker

Do not attempt to move the cooker by pulling on the doors or handles. Open the door and grasp the frame of the cooker, taking care that the door does not shut on your fingers.

Take care to avoid damage to soft or uneven floor coverings when moving the appliance. Some cushioned vinyl floor coverings may not be designed to withstand sliding appliances without marking or damage.

Gas & Electrical connection

Please refer to installation instructions for the Gas & Electrical Safety Regulations and the Ventilation Requirements.

In your own interest, and that of safety, it is the law that all gas appliances be installed by competent persons. Corgi registered installers undertake to work to satisfactory standards.

Disconnection of gas and electric appliances should always be carried out by competent persons.

Warning: This appliance must be earthed.

If the ignition fails:

- Check there is a spark when the ignition button is depressed.
- If there is no spark, check that the electricity supply is switched on at the socket.
- Check that the gas supply is switched on.

Stability bracket

If the cooker is to be fitted with a flexible inlet connection, a stability bracket should also be fitted to engage in the back of the cooker. Make sure this is re-engaged whenever you move the cooker for cleaning.

The Gas Consumer Council (GCC) is an independent organisation which protects the interests of gas users. If you need advice, you will find the telephone number in your local telephone directory under Gas.

The cooling fan

When the appliance is switched on, you may hear the cooling fan come on. This keeps the fascia and control knobs cool during grilling / cooking and will continue to operate for up to 15 minutes after the appliance has been switched off.

During oven use the fan may cycle on and off. Should any fault occur with the cooling fan, the appliance will require servicing. Contact Customer Support.

Introduction

Environmental Protection

We are committed to protecting the environment and operate an Environmental Management System which complies with BS EN ISO 14001:1996.

Disposal of packaging

- All our packaging materials are recyclable and environmentally friendly.
- Please help us to protect our environment by disposing of all packaging in an environmentally friendly manner.
- Please contact your local authority for the nearest recycling centre.

Caution: Packaging materials can pose a risk of suffocation - keep away from children.

Storage Compartment

Storage compartment

Your appliance has a generous storage compartment, located beneath the right-hand side oven.

The storage compartments should only be used to store oven furniture.

Baking trays and roasting tins may be stored in the compartment.

Do not store items with plastic or wooden handles in the compartments, as they may be damaged by heat from the oven.

Do not store flammable liquids, even when cold, in the storage compartments, as they may catch fire. Do not store flammable items - ie; chip pans.

Do not store food / canned items in the storage compartments. **Do not use the compartments as a food warming facility.**

Be Safe - Not Sorry

When you are cooking, keep children away from the vicinity of the appliance.

This product is designed as a domestic cooking appliance for the preparation and cooking of domestic food products, and should not be used for any other purpose.

- Remove all packaging from the appliance before using for the first time.
- Make sure you read and understand the instructions before using the appliance.
- Keep electrical leads short so they do not drape over the appliance or the edge of the worktop.
- Keep all flammable materials (such as curtains and furnishings) away from the appliance.
- Parts of the appliance may be hot during or immediately after use. Allow sufficient time for the appliance to cool after switching off.
- Switch off the electricity supply before cleaning the appliance.
- Do not drape tea towels over the flue vents or door handles, as this creates a fire hazard.
- When opening the appliance door, take care to avoid skin contact with any steam which may escape from the cooking.

- Do not use aluminium foil to cover the grill pan, or put items wrapped in foil under the grill, as this creates a fire hazard.
- Use oven gloves when removing hot food / dishes from the oven or grill. The oven / grill and utensils will be very hot when in use.
- Do not use foil on oven shelves or allow it to block the oven flue, as this creates a fire hazard, and prevents heat circulation.
- When cooking heavy items - eg; turkeys - do not pull the oven shelf out with the item still on the shelf.
- *Drop-down doors (where fitted):* Do not place items on the door when open.
- Never use the appliance for heating a room.
- As with all gas appliances, it is recommended that your appliance is serviced regularly.
- **Warning:** This appliance must be earthed.
- **All installation, servicing and maintenance** work should be carried out by a competent person who will comply with current Regulations, Standards and Requirements.

When you have finished cooking check that all controls are in the off position.

Minute Minder

Initial display

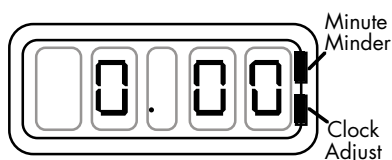

The digital timer enables you to set the time of day (24 hour clock) and the minute minder alarm.

Setting the "Time of Day"

1. Switch on the electricity supply to the appliance.
The clock adjust LED will flash (bottom, right hand side).
2. Set the time of day with the *plus* and *minus* buttons.
4. The time will be set 5 seconds after the last plus or minus operation, the LED will stop flashing and remain illuminated.

Changing the time of day

1. Press the function button twice.
2. Set the time of day with the *plus* and *minus* buttons.
3. The time will be set 5 seconds after the last plus or minus operation, the LED will stop flashing and remain illuminated

Setting the minute minder

1. Press and release the *Function* button to change the display from clock to minute minder - the Minute Minder LED will flash (top right hand side)..
2. Use the *plus* and *minus* buttons to set the length of time before the alarm tone will sound.

The maximum period which may be set is 23 hours 59 minutes.

During countdown, the minute minder has priority on the display, which will show (in *hours / minutes*) the time remaining.

When countdown is complete, the tone will sound for 2 minutes, or it can be reset with one touch of any button.

To cancel the minute minder, press the function button and run down the set time with the *minus* button.

The display will revert to show the time of day, and the minute minder will not sound.

Note:

If all three timer buttons are pressed together at the same time, for longer than three seconds, the timer display will go out. The easiest way to reset it is to press any one of the clock buttons, the will re illuminate the clock.

Using the Hob

When you are cooking, keep children away from the vicinity of the appliance.

Ignition

Push in and turn the selected control knob anticlockwise to the large flame symbol and press the IGNITION SWITCH until the burner lights. Turn the control knob to the required setting.

Adjust the burner flame so that it does not extend over the pan base.

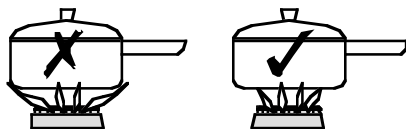

To turn off, push in the control knob and turn clockwise until the dot on the control knob is below the line on the fascia panel.

To simmer

The simmer position is marked by the SMALL FLAME symbol.

Once lit turn the selected control knob anticlockwise past the LARGE FLAME symbol (FULL ON) to the SMALL FLAME symbol.

You may hear a slight popping noise when the hob burners are operating and this is quite normal, but if anything about the cooker appears unusual, such as change in flame appearance, or the operation of controls - seek expert advice.

Pans

For optimum safety and performance, we recommend flat bottomed pans with a base diameter of minimum 100mm (4") and maximum 250mm (10"), which are stable in use.

Avoid using old misshapen pans or any pan which is unstable when placed on a flat surface.

Turn pan handles to a safe position so they are out of reach of children, not overhanging the appliance and cannot be caught accidentally.

Position pans over the centre of the burners, resting on the pan supports. If positioned off centre, smaller pans may be unstable.

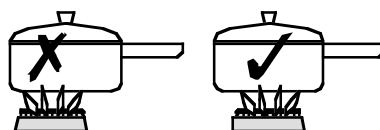

When cooking with fat or oil, never leave unattended.

Commercial simmering aids should not be used as they create excessive temperatures that can damage the surface and may cause a hazard.

When you have finished cooking check that all controls are in the off position.

Pan supports

Always make sure the pan supports are replaced correctly, and located in the hob spillage well.

Using the Hob

The fold down lid

Caution: Glass lids may shatter when heated. Turn off all the burners before shutting the lid.

Any spillage should be removed from the surface of the lid before opening.

When opening and closing the lid, use the cooler outer sides of the lid trim.

The lid must be opened fully, so there is no danger of it closing while the hob is being used.

The appliance is fitted with a switch-back system, which will automatically turn off the hot plate controls if they are inadvertently left on as the lid is closed.

The lid is not intended to be used as a work surface, as it becomes hot when any part of the cooker is in use, and the surface may be scratched if items with rough or sharp surfaces are placed on it.

Using the Grill

Caution: Accessible parts may be hot when the grill is used. Young children should be kept away.

Ignition

Open the grill door. Push in and turn the grill control knob anticlockwise to the 'full on' position. Hold the control knob in and operate the ignition button or hold a lighted match or taper to the burner.

Do not hold the control knob in for more than 15 seconds. If after 15 seconds the burner has not lit, release the control knob and wait at least one minute before attempting a further ignition of the burner.

Note that on some models it is not necessary to hold the control in after turning anticlockwise to the "full on" position.

In the event of the burner flames being accidentally extinguished, turn off the burner control and do not attempt to reignite the burner for at least one minute.

A few seconds after the flame has established, the safety valve will open and the control knob can be released.

Turn the control knob to the required setting.

Important: Keep the grill door open when the grill is on.

When slower cooking is required the grill can be turned down anti-clockwise to a slightly reduced setting, past the large flame symbol (full on), to the small flame symbol. This can be used in conjunction with use of the different grilling positions.

Only use the grill burner between the large and small flame symbol.

To turn off, push in the control knob and turn it clockwise to the "off" position.

Preheating

For best cooked results, always preheat the grill for about 3 minutes.

Aluminium foil

Note that using aluminium foil to cover the grill pan - or putting items wrapped in foil under the grill - can create a fire hazard.

Using the Grill

Detachable grill pan handle

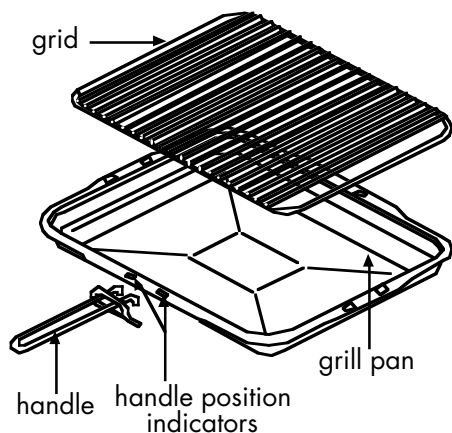

Place the handle over the edge of the grill pan, at the narrow side edges. Slide the handle to the centre, and locate between the handle position indicators.

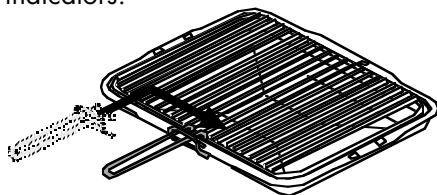

The handle should be removed from the pan during grilling, to prevent overheating.

The handle is designed for removing / inserting the grill pan under the grill when grilling.

If cleaning the grill pan when it is hot, use oven gloves to move it. *Do not* use the handle to pour hot fats from the grill pan.

Food for grilling should be positioned centrally on the trivet.

Grilling

Important: Keep the grill door open when the grill is on.

The grill is variable. The speed of grilling can also be adjusted by selecting a higher or lower shelf position.

We recommend using a higher shelf position for toasting, and for cooking foods such as bacon, sausages or steaks.

For thicker foods such as chops or chicken joint pieces, use a middle to low shelf position.

The grill trivet, which is in the grill pan, may be inverted to give a high or low position or the trivet may be removed.

1. The HIGH trivet position is suitable for toasting bread.
2. The LOW trivet position is suitable for grilling all types of meat and fish.
3. With the grill trivet removed the food is placed directly on the base of the grill pan - eg; when cooking whole fish or browning dishes such as cauliflower cheese.

Using the Grill

Grilling guide

Grill shelf positions

Shelf positions are counted from the top down - shelf 1 is the highest.

Grilling times

The times given in the grilling guide are based on a grill pre-heated at full rate. The grilling times given are approximate, as differences in thickness, size of portion and personal preference will influence timing. For optimum results when grilling, the temperature should be varied where required, using the full on and turn down settings.

Food	Shelf Position	Grill Trivet Position	Approximate Grilling Time (preheated grill)
Bread			
Toast; 2 rounds	1	High	2 - 3 mins per side
Toast; 3 - 4 rounds	1	High	2 - 3 mins per side
Bread, buns, teacakes	2	Low	2 - 3 mins per side
Cheese on toast	1	High	6 - 7 mins
Meat			
Bacon rashers	1	High	8 - 15 mins
Sausages	1	High	12 - 15 mins
Steak; rare	1	High	7 - 10 mins
Steak; medium	2	High	10 - 15 mins
Steak; well done	2	High	15 - 20 mins
Lamb chops	2	High	10 - 15 mins
Pork chops	3	High	15 - 25 mins
Gammon steaks	1	High	12 - 15 mins
Poultry			
Chicken fillets	4 or 5 (depends on thickness)	Low	20 - 30 mins
Fish			
Fish fillets	4	Low	10 - 15 mins

Using the ovens

Caution: Accessible parts may be hot when the ovens are used. Young children should be kept away.

The cooker has two conventional gas ovens.

Ignition

Open the oven door. Push in and turn the control knob to the full on position (gas mark 9). Hold the control knob in and operate the ignition button (if fitted) or hold a lighted match or taper to the burner.

Do not hold the control knob for more than 15 seconds, if after 15 the burner has not lit, release the control knob and wait at least one minute before attempting a further ignition of the burner.

A few seconds after the flame has established, the control knob can be released.

Turn the control knob to the required gas mark setting.

In the event of the burner flames being accidentally extinguished, turn off the burner control and do not attempt to re-ignite the burner for at least one minute.

To turn off, push in the control knob and turn clockwise until the dot on the control knob is below the line on the fascia panel.

Preheating

The oven must be preheated for 15 minutes when cooking frozen or chilled foods, and we recommend preheating for yeast mixtures, batters, soufflés, and whisked sponges.

Notes:

As part of the cooking process, hot air is expelled through a vent at the top of the oven(s). When opening the oven door, care should be taken to avoid any possible contact with potentially hot air, since this may cause discomfort to people with sensitive skin. We recommend that you hold the underneath of the oven door handle.

If you find that over a period of time, the oven becomes hotter when used at a particular gas mark, the thermostat may need to be replaced.

Using the ovens

Baking tray and roasting tins

For best cooked results and even browning, the maximum size baking trays and roasting tins that should be used are as follows;

Baking tray 290mm x 270mm

This size of baking tray will hold up to 16 small cakes.

Roasting tin 320mm x 270mm

We recommend that you use good quality cookware. Poor quality trays and tins may warp when heated, leading to uneven baking results.

Shelf positions

The oven shelf must be positioned with the upstand at the rear of the oven and facing upwards.

To allow for heat circulation, position baking trays and roasting tins on the middle of the shelves when cooking with more than one shelf.

When cooking 2 trays or items, remove the top item when it is cooked and raise the lower item to the higher shelf to finish cooking, or where additional browning of the bases is required - eg; pies and pastries - interchange part way through cooking.

If you prefer darker cooked results, cook on a higher shelf, for paler results use a lower shelf.

Using the ovens

Zones of heat

The temperature at the centre of the oven corresponds with the selected gas mark and is slightly higher towards the top of the oven and slightly lower towards the oven base.

These zones of temperature can be useful as different dishes requiring different temperatures can be cooked at the same time, when more than one shelf is used.

The temperature at the oven base is suitable for cooking baked vegetables, baked fruit, milk pudding etc, and for warming bread rolls, soup, coffee or oven proof plates and dishes.

If you find that over a period of time the oven becomes hotter when used at a particular gas mark, the thermostat may need to be replaced.

Cooking frozen & chilled foods

- Always preheat the oven.
- When cooking frozen or chilled foods, please follow the manufacturer's instructions.
- If cooking more than one tray or item, cooking times may need to be increased.
- Please ensure that foods are piping hot before consumption.
- Due to the many variations of frozen and chilled foods, always use the temperature setting stated on food packaging.
- Never overload the tray - eg; oven chips should be placed onto the

baking tray in one even layer for satisfactory cooking.

- Follow the cooking times given on packaging but remember they are only intended as a guide and do not take individual preferences into account.
- Always cook frozen convenience foods straight from the freezer unless packaging advises otherwise.

Slow cooking

Make sure that frozen foods are thoroughly THAWED before cooking.

Do not slow cook joints of meat or poultry weighing more than 2½kg / 4½lb.

Always use the top half of the oven for slow cooking.

For roasting joints of meat or poultry, and for pot roasts preheat the oven to gas mark 6 and cook for 30 minutes, then adjust the oven control to the '**S**' slow setting for the remainder of the cooking time.

Slow cooking times will be about three times as long as conventional cooking times.

Baking guide

Please note that the times and temperatures stated in the baking guide are only intended for reference only - refer to your recipe.

Using the oven

Baking guide Dish	Recommended gas mark	Shelf position	Approximate cooking time
Scones Meringues	7 "S" slow setting	top to middle middle to bottom	8 - 15 mins 3 - 4 hours
Cakes Small cakes Whisked sponge Swiss roll Victoria sandwich (2 x 180mm / 7") Genoise sponge Madeira (180mm/7") Gingerbread Very rich fruit cake (205mm / 8") Semi rich fruit cake (205mm /8")	5 5 6 4 4 3 2 1 or 2 2 or 3	middle to top middle to top middle to top middle to top middle middle to bottom middle to bottom middle to bottom middle to bottom	15 - 25 mins 20 - 30 mins 8 - 15 mins 20 - 35 mins 20 - 30 mins 1¼ - 1½ hours 1 - 1½ hours 3½ - 4 hours 2½ - 3 hours
Pastry Rough puff Flaky / Puff Shortcrust Flan Choux	7 7 6 6 6	middle to top middle to top middle to top middle to top middle to top	15 - 45 mins 15 - 45 mins 15 - 45 mins 15 - 45 mins 20 - 45 mins
Biscuits Shortbread fingers Nut brownies Flapjacks Ginger nuts	3 3 4 5	middle to top middle to bottom middle to top middle to top	20 - 30 mins 12 - 18 mins 20 - 40 mins 7 - 12 mins
Puddings Rice pudding Baked custard Bread and butter Hot soufflé Fruit crumble	2 2 or 3 3 4 5	middle to bottom middle to bottom middle middle to top middle to top	2 - 2½ hours 1 - 1¼ hours 1 - 1¼ hours 40 - 50 mins 30 50 mins
Bread (2 x 500g) Bread (1 x 1kg)	7 7	middle to top middle to top	20 - 40 mins 30 - 45 mins

Using the Oven

Traditional fruit cakes

It should be remembered that ovens can vary over time, therefore cooking times can vary, making it difficult to be precise when baking fruit cakes.

It is necessary therefore, to test the cake before removal from the oven. Use a fine warmed skewer inserted into the centre of the cake. If the skewer comes out clean, then the cake is cooked.

- Do not attempt to make Christmas cakes larger than the oven can cope with, you should allow at least 25mm (1 inch) space between the oven walls and the tin.
- Always follow the temperatures recommended in the recipe.
- To protect a very rich fruit cake during cooking, tie 2 layers of brown paper around the tin.
- We recommend that the cake tin is not stood on layers of brown paper, as this can hinder effective circulation of air.
- Do not use soft tub margarine for rich fruit cakes, unless specified in the recipe.
- Always use the correct size and shape of tin for the recipe quantities.

Roast turkey

Roasting turkey involves cooking two different types of meat - the delicate light breast meat, which must not be allowed to dry out, and the darker leg meat, which takes longer to cook.

The turkey must be roasted long enough for the legs to cook, so frequent basting is necessary. The breast meat can be covered once browned.

- Always make sure that the turkey is completely thawed and that the giblets are removed before cooking.
- Turkey should be roasted at gas mark 4 for 20 minutes per 1lb, plus 20 minutes, unless packaging advises otherwise.
- The turkey can be open roasted, breast side down, for half of the cook time, and then turned over for the remainder of the cooking time.
- If the turkey is stuffed, add 5 minutes per 1lb to the cooking time.
- If roasting turkey covered with foil, add 5 minutes per 1lb to the cooking time.

To test if the turkey is cooked, push a fine skewer into the thickest part of the thigh. If the juices run clear, the turkey is cooked. If the juices are still pink, the turkey will need longer cooking.

Using the Oven

Roasting guide

The times given in the roasting guide are only approximate, because the size and age of the bird will influence cooking times as will the shape of a joint and the proportion of bone.

Frozen meat should be thoroughly thawed before cooking. For large joints it is advisable to thaw overnight.

Frozen poultry should be thoroughly thawed before cooking. The time required depends on the size of the bird, eg; a large turkey may take up to 48 hours to thaw.

Use of a trivet with a roasting tin will reduce fat splashing and will help to keep the oven interior clean. Alternatively, to help reduce fat splashing, potatoes or other vegetables can be roasted around the meat / poultry.

Notes:

- When cooking stuffed meat or poultry, calculate the cooking time from the total weight of the meat plus the stuffing.
- For joints cooked in foil or covered roasters, and for lidded casseroles, add 5 minutes per 450g (1lb) to the calculated cooking time.
- Smaller joints weighing less than 1.25kg (2½lb) may require 5 minutes per 450g (1lb) extra cooking time.
- Position the oven shelf so that the meat or poultry will be in the centre of the oven.
- It is recommended that the appliance is cleaned after open roasting.

Cook in oven at Gas Mark 5		Approximate Cooking Time (preheated oven)
Beef	Rare Medium Well done	20 minutes per 450g (1lb), plus 20 minutes 25 minutes per 450g (1lb), plus 20 minutes 30 minutes per 450g (1lb), plus 30 minutes
Lamb	Medium Well done	25 minutes per 450g (1lb), plus 25 minutes 30 minutes per 450g (1lb), plus 30 minutes
Pork		35 minutes per 450g (1lb), plus 35 minutes
Poultry		20 minutes per 450g (1lb), plus 20 minutes

Cleaning

Caution: Any cleaning agent used incorrectly may damage the appliance.

Always let the cooker cool before cleaning.

Some cooking operations generate considerable amount of grease, this combined with spillage can become a hazard if allowed to accumulate on the appliance through lack of cleaning. In extreme cases this may amount to misuse of the appliance and could invalidate your guarantee.

It is recommended that the appliance is cleaned after open roasting

Do not use caustic, corrosive or abrasive cleaning products, products containing bleach, coarse wire wool or any hard implements, as they will damage the surfaces.

All parts of the cooker can be safely cleaned with a cloth wrung out in hot soapy water.

Burner caps and heads

Important: Allow burners to cool before cleaning.

Caution: Hotplate burners can be damaged by soaking, automatic dishwashers (or dishwasher powders / liquids), caustic pastes, hard implements, coarse wire wool, and abrasive cleaning pastes.

For the burners to work safely, the slots in the burner head where the flames burn need to be kept clear of deposit. Clean with a nylon brush, rinse, and dry thoroughly.

Hotplate burners may be cleaned with a moist soapy pad, eg; "Brillo".

Important: The burner caps and heads must be repositioned correctly so that they sit squarely onto the hob as shown below.

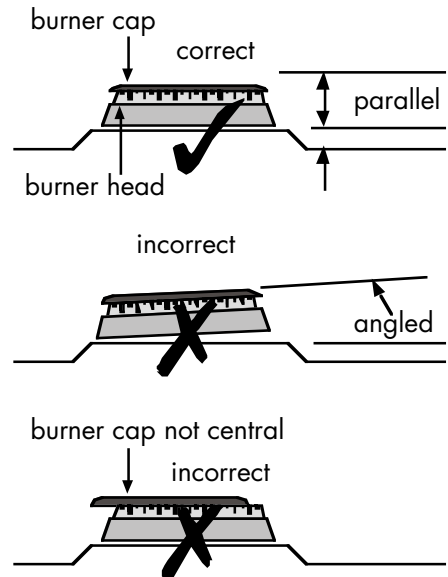

Cleaning

Painted, plastic, metal finish & metal finish parts (where fitted)

CONTROL KNOBS & PROGRAMMER BUTTONS, PAINTED METAL DOOR & FASCIA PANELS, SIDE PANELS, HANDLES.

Only use a clean cloth wrung out in hot soapy water. Take extra care when cleaning over symbols on fascia panels.

Vitreous Enamel Parts

GRILL PAN & GRILL COMPARTMENT, HOB TOP & PAN SUPPORTS, OVEN COMPARTMENT.

Use a mild cream cleaner - eg; "Cif".

Stubborn marks may be removed using a moistened "Brillo" pad.

The pan supports and grill pan may be cleaned in a dishwasher, or with a nylon brush in hot soapy water.

Chrome plated parts

OVEN SHELF & SHELF RUNNERS, GRILL PAN RUNNERS, GRILL PAN TRIVET, GRILL PAN HANDLE

Use a moist soap pad, eg; "Brillo".

Note: Oven shelf runners can be removed for cleaning. Grasp the runners and slide out of the hanging holes as shown.

Note: These items may also be cleaned in a dishwasher.

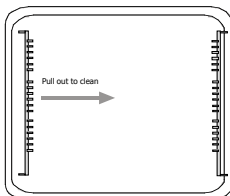

Stainless steel surfaces

FASCIA PANEL, HANDLES & DOORS

Only use a clean cloth wrung out in hot soapy water, and dry with a soft cloth.

Stubborn marks can be removed using Luneta. We recommend that you clean the whole of the stainless steel area to maintain a uniform finish. Supplies can be purchased from the Customer Care Centre.

Do not use undiluted bleach or any products containing chlorides as they can permanently damage the steel.

Extra care should be taken when cooking food in salted water. Some foods are corrosive eg; vinegar, fruit juices and especially **salt** - they can mark or damage stainless steel if they are left on the surface. Wipe any spillage immediately, taking care to avoid burning your hands.

Sharp objects can mark the surface of stainless steel, but will become less noticeable with time.

To maintain the finish of the stainless steel, or to remove any greasy marks, rub the stainless steel surface sparingly with a minimum amount of "Johnson's Baby Oil".

Do not use cooking oils, as these may contain salt which can damage the stainless steel surface.

Cleaning

Glass parts

GLASS DOOR PANELS

Do not use abrasives or polishes as they will scratch and damage the glass.

Use a mild cream cleaner - eg; "Cif".
Rinse away excess cleaner and dry with a soft cloth.

Warning: Do not operate the appliance without the glass panel correctly fitted.

Important: the inner door glass panel can be removed for cleaning but it must be replaced the right way up (so the reflective side - if fitted - faces inwards), and pushed fully in to the **stop** position. To remove the glass panel, open the door wide, hold the top and bottom edges and slide out.

Cast iron pansupports

After cooking allow the pansupports to cool completely before attempting to remove or clean.

Before cleaning, remove any excess fat with kitchen paper.

The pansupports can be cleaned with hot soapy water and a nylon brush. If any food residue is left on them leave them to soak for a few minutes in hot soapy water before attempting to clean it. Do not use caustic pastes, abrasive cleaning powders, coarse wire wool or any hard implements, as they will damage the surface.

Do not clean in a dishwasher.

Maintenance

All models with side lights.

To replace a light bulb
(if fitted)

Warning: Switch off the electricity supply to the cooker at the socket, to avoid the risk of electric shock. Wait until the oven is cool, then remove the oven shelves.

Grasp the lens cover on the light fitting and pull it away from the side of the oven. Unscrew the bulb.

All models with rear lights

Fan Assisted Ovens

To replace an oven light bulb
(If fitted)

Warning: Switch off the electricity supply to the cooker at the socket, to avoid the risk of electric shock.

Wait until the oven is cool, then remove the shelves.

The oven light is at the rear of the oven cavity.

Remove the loose oven back - unscrew the 4 securing screws (one at each corner).

Unscrew the lens cover (turn anticlockwise). Unscrew the bulb and replace. Replace lens cover.

Replace oven back.

Conventional Ovens

To replace an oven light bulb
(if fitted)

Warning: Switch off the electricity supply to the appliance at the socket, to avoid the risk of electric shock.

Wait until the oven is cool, then remove the oven shelves.

The oven light is at the rear of the oven cavity.

Unscrew the lens cover (turn anticlockwise). Unscrew the bulb and replace. Replace lens cover.

Please note that the oven light bulb is not covered by guarantee.

Installation Instructions

Before you start: Please read the instructions. Planning your installation will save you time and effort.

Prior to installation, ensure that the local distribution conditions (nature of the gas and gas pressure) and the adjustment of the appliance are compatible. The adjustment conditions are stated on the data badge.

This appliance is not connected to a combustion evacuation device. It shall be installed and connected in accordance with current installation regulation. Particular attention shall be given to the relevant requirements regarding ventilation.

In your own interest and that of safety, it is the law that all gas appliances be installed and serviced by competent persons. CORGI registered installers undertake to work to satisfactory standards.

Where regulations or standards have been revised since this handbook was printed, always use the latest edition.

In the UK the regulations and standards are as follows:

1. Gas Safety Regulations 1996 (Installation and Use).
2. Building Regulations - Issued by the Department of the Environment.
3. Building Standards (Scotland) (Consolidated) - Issued by the Scottish Development Department.
4. The current I.E.E. Wiring Regulations.
5. Electricity at Work Regulations 1989.
6. BS 6172 Installation of Domestic Gas cooking Appliances
7. Installation & Servicing Instructions for this appliance.

Ventilation Requirements

The room containing the appliance should have an air supply in accordance with BS 5440: Part 2: 1989:

- All rooms require an openable window, or equivalent, and some rooms will require a permanent vent as well.
- For room volumes up to 5m³ an air vent of 100cm² is required.
- If the room has a door that opens directly to the outside, or the room exceeds 10m³, NO AIR VENT is required.
- For room volumes between 5m³ and 10m³ an air vent of 50cm² is required.
- If there are other fuel burning appliances in the same room, BS 5440: Part 2: 1989 should be consulted to determine the air vent requirements.
- This appliance must not be installed in a bed sitting room of less than 20m³ or in a bathroom or shower room.

Windows and permanent vents should therefore not be blocked or removed without first consulting a CORGI gas installer.

Failure to install appliances correctly is dangerous and could lead to prosecution.

Installation Instructions

Whilst every care is taken to eliminate burrs and raw edges from this product, please take care when handling - we recommend the use of protective gloves during installation.

Moving the cooker

Please note that the weight of this appliance is approximately **76kg** (unpacked).

Take care if the appliance needs to be lifted during installation - always use an appropriate method of lifting.

Do not attempt to move the cooker by pulling on the doors or handles. Open the door and grasp the frame of the cooker, taking care that the door does not shut on your fingers.

Take care to avoid damage to soft or uneven floor coverings when moving the appliance. Some cushioned vinyl floor coverings may not be designed to withstand sliding appliances without marking or damage.

Clearances & Dimensions

Appliance dimensions

All sizes are nominal, and some variation is to be expected. The 'depth' of the cooker, as given below, is to the front of the door and excluding knobs and handles.

Width	1100mm
Depth	600mm
Height (adjustable)	900 - 915mm

Clearances

This cooker may be fitted flush to base units. However, for models with side opening doors, we recommend a side clearance of 60mm between the cooker and any side wall or protruding cabinet, to allow the door to open fully.

No shelf or overhang or cooker hood shall be closer than a minimum of 650mm, but check with cooker hood manufacturer's recommendations.

The cooker must have a side clearance above hob level of 90mm up to a height of 400mm.

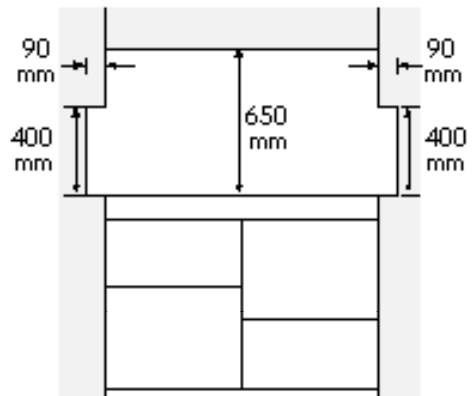

Installation Instructions

Stability bracket

If the cooker is fitted with a flexible connection, a stability bracket should be fitted to engage in the back of the cooker. A stability bracket can be bought from your local supplier.

A stability bracket can be fitted as follows:

1. Place the cooker in position and draw a pencil line level with the front edge.
2. Mark the centre of the cooker to give the centre line for the bracket.
3. Remove the cooker and mark off 450mm from the pencil line to locate the front edge of the lower bracket.

4. Fix the bracket to the floor.

Measure from floor level to engagement edge in the back of the cooker and add 3mm.

5. Assemble the underside of the top part of the bracket to this height.

Levelling

Place a spirit level on a baking sheet onto an oven shelf.

The cooker is fitted with levelling feet and locknuts at the front, and wheels at the rear.

Adjustment of wheel height can be made with a screwdriver through the hexagonal hole in the front plinth.

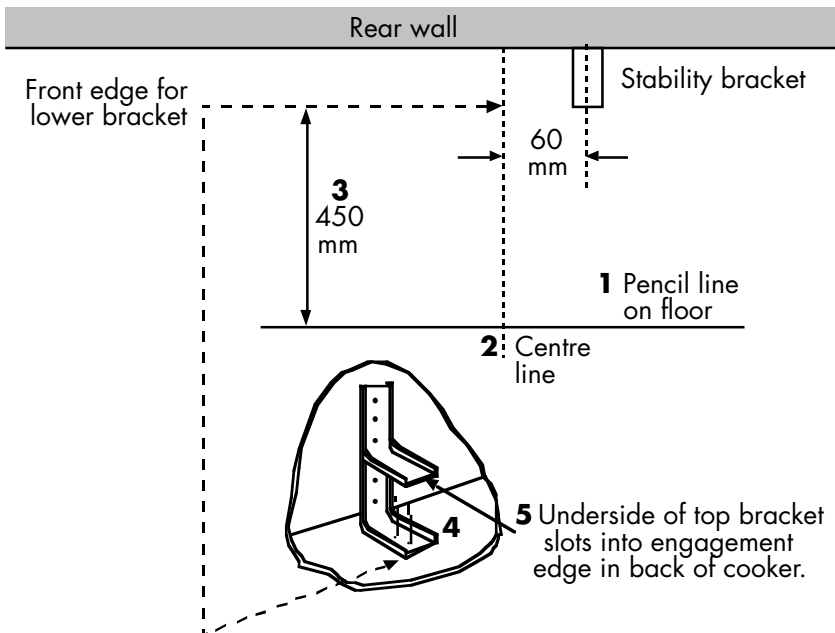

Installation Instructions

Connect to the gas supply

The inlet to the cooker is ½" BSP internal, situated at the rear centre of the appliance.

Use a 900 - 1125 mm length of flexible connector.

Ensure that all pipe work is of the correct rating for both size and temperature.

Natural Gas - Flexible connections should comply with BS 669. Parts of the appliance likely to come into contact with a flexible connector have a temperature rise of less than 70°C.

After installation, make sure all connections are gas sound.

Important: - ensure that you route all mains and electrical cables and flexible tubing well clear of any adjacent heat source.

Installation Instructions

Connect to the electricity supply

Warning: This appliance must be earthed.

The flexible mains lead is supplied connected to a BS 1363 fused plug, having a fuse of 3 amp capacity.

If this plug does not fit the socket in your home, it should be replaced with a suitable plug as outlined below.

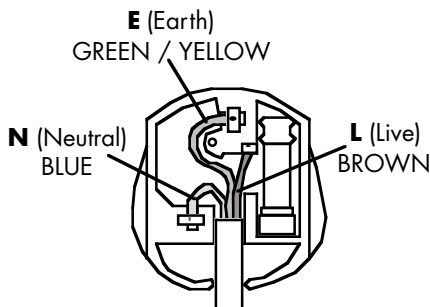

Use a **3 amp** fuse
in a 13 amp plug.

The wires in the mains lead are coloured in accordance with the following code:

Green and yellow = Earth,
Blue = Neutral,
Brown = Live.

As the colours of the wires in the mains lead for the appliance may not correspond with the coloured markings identifying the terminals in your plug, proceed as follows:

1. The wire which is coloured green and yellow must be connected to the terminal marked **E** (Earth) or coloured Green.
2. The wire which is coloured blue must be connected to the terminal marked **N** (Neutral), or coloured Black.
3. The wire which is coloured brown must be connected to the terminal marked **L** (Live), or coloured Red.

The plug and socket must be accessible after installation.

Should the appliance mains lead ever require replacing, we recommend that this is carried out by a qualified electrician who will replace it with a lead of the same size and temperature rating.

Installation Instructions

Commissioning

Burner aeration

All burners have fixed aeration and no adjustment is possible.

Pressure setting

G20 Natural Gas @ 20 mbar

Pressure test point

Use the oven injector

Ignition

All burners are ignited by pressing the ignition switch on the fascia. When the burner has lit release the ignition switch.

Hob - Turn the tap to the 'full on' position, wait a second before pressing the ignition switch.

Grill - Open the grill door. Push in and turn the tap to the 'full on' position. Hold the control knob in and operate the ignition button. A few seconds after the flame has been established release the control knob.

Ovens - Open the oven door. Push in and turn the control knob to the full on position. Hold the control knob in and operate the ignition button. A few seconds after the flame has established, the control knob can be released.

Before leaving the installation

1. Place all the loose parts of the cooker into position.
2. Show the customer how to operate the cooker and give them this handbook.

Thank you.

Technical Data

Data badge - Lower part of front frame.

220 - 240V ~ 50Hz

Type of gas

This cooker must only be used with Natural Gas only as specified on the appliance data badge.

Warning: This cooker must be earthed.

Spark generators

Two mains powered 6 outlet, two terminals earthed out to chassis on one generator.

Gas category

Natural Gas - I2H

Grill

Grill burner is surface combustion type. Spark gaps 3 - 4mm.

Pressure setting

G20 Natural Gas @ 20 mbar

Hob

Burners have burner heads and caps which are removable for cleaning. Concealed electrodes to each burner.

Pressure test point

Use the oven injector.

Aeration - Fixed.

Ovens

Oven burners are sheet steel, with pierced ports. Spark gaps 3 - 4mm. Flame supervision - Thermoelectric type. Thermostat phial; front centre of oven roof.

Appliance class

Class 1, Freestanding

Countries of destination

GB - Great Britain

Electrical supply

Gas	Burner	Nominal Rate Qn (at 230V)	Grammes per hour		Injector size
			Butane	Propane	
Natural Gas	Grill	2.4kW	-	-	1.15mm
	Hob small x 2	1.0kW	-	-	77
	medium x 3	2.0kW	-	-	104
	large x 1	3.0kW	-	-	129
	wok x 1	3.5kW	-	-	63+121
	Ovens x 2	2.5kW	-	-	180 amal
	Total heat input	Qn 21.9kW	-	-	-

Belling Customer Care

In case of difficulty within the UK and Northern Ireland, please call
Belling Customer Care Centre Helpline on

0870 444 9939

When you dial this number you will hear a recorded message and be given a number of options. This indicates that your call has been accepted and is being held in a queue. Calls are answered in strict rotation as our Customer Care Representatives become available.

Opening Hours for Customer Care

Monday to Friday	8am - 8pm
Saturday	8.30am - 6pm
Sunday	10am - 4pm

Enter appliance numbers here for future reference:

Model No									
<input type="text"/>	<input type="text"/>	<input type="text"/>	<input type="text"/>	<input type="text"/>	<input type="text"/>	<input type="text"/>	<input type="text"/>	<input type="text"/>	<input type="text"/>
Serial No									
<input type="text"/>	<input type="text"/>	<input type="text"/>	<input type="text"/>	<input type="text"/>	<input type="text"/>	<input type="text"/>	<input type="text"/>	<input type="text"/>	<input type="text"/>

Please ensure you have the above details (Model No and Serial No) to hand when calling Belling Customer Care. They are essential to booking your call.



Stoney Lane, Prescott, Merseyside, L35 2XW