

Forum

Slot-in Double Cavity Electric Cookers

INSTALLATION AND USER INSTRUCTIONS

Models: 317, 327, 329, 331, 332, 335, 371





Contents

- Introduction**.....3
- Installing Your Cooker**4-5
- For your own safety - Never**6
- Always**7
- Know your Cooker**8
- Using the Timer**
- 3 Button Clock/Minute Minder**.....9
- Minute Minder Operation**.....10
- 5 Button Clock/Programmer**.....11
- Setting the Time of Day**.....12
- Automatic Cooking Programmes**.....13-14
- Using the Hob**.....15
- Safety requirements for Deep Fat Frying**.....16
- Using the Grill**.....17
- Use of the Grill Pan Handle**.....18
- Using the Top Oven**.....19
- Using the Main Oven**.....20
- Oven Cooking Guides**21
- Care and Cleaning**22-23
- Replacing oven lamp**.....23
- Something Wrong With Your Cooker**.....24
- Customer Care** 25

This appliance conforms to the following EEC Directives:

Low Voltage Equipment

73/23/EEC

93/68/EEC

Electromagnetic Compatibility

89/336/EEC

92/31/EEC

93/68/EEC



Introduction

Your Belling Cooker

Thank you for purchasing a new Belling Forum Cooker. Its stylish and practical design will enhance your kitchen and make cooking a pleasure. It features a fan oven or conventional oven, with a separate grill or grill/top oven and a hob with solid hotplates. Some models feature a fully programmable clock/timer with a minute minder and automatic oven switch on and off or a clock/minute minder. Even if you have used an electric cooker before, it is important that you read these instructions thoroughly before starting to cook, paying particular attention to the installation and safety instructions.

Getting Help

If you have any problems with installing, operating, or cooking with your Belling Cooker, please check through these instructions thoroughly to make sure that you have not missed anything. If you still need help, then please contact (including a daytime telephone number if possible):

Consumer Relations Department
Belling Appliances Ltd.
Talbot Road
Mexborough
South Yorkshire
S64 8AJ
Tel: 01709 579902

Please quote the cooker model and serial number with all enquiries. This can be found on the rating plate on the plinth below the oven door.

WARNING! For your own safety, make sure that these instructions on installation, use and maintenance are followed.

We advise you to keep these instructions in a safe place for future reference. If you sell or transfer ownership of this product, please pass on these instructions to the new owner.

Installing your cooker

Unpacking After unpacking your cooker, make sure that you remove all the packing from the oven and grill, and any stickers from the oven door and the hob.
Examine your cooker for any damage, make sure there is no damage to your cooker.
If there is or there is anything missing, please contact your supplier for advice

Siting/Moving the Cooker Your cooker is heavy, so be careful when moving or positioning it. Do not try to move the cooker by pulling on the doors or handles. The Belling Forum is designed to fit between 600mm deep cabinets, spaced a minimum of 500mm apart. It can also be used freestanding, with a cabinet to one side, in an angled corner setting or with its back to a wall.
The cooker is a type X appliance, as such, adjacent side walls which project above hob level must not be nearer to the cooker than 150mm (6") Any overhanging surface or cooker hood should be at least 650mm (25 1/2 ") above the cooker hob. We do not recommend positioning the cooker below wall cupboards, as the heat and steam from the cooker may cause damage to the cupboard and its contents.
Whatever the position, remember to leave enough room for the cooker to be pulled out for cleaning and service.
Movement of your cooker is most easily achieved by lifting the front as follows. Open the Top Oven/Grill door sufficiently to allow a comfortable grip on the underside front edge of the oven roof, avoiding any grill elements or oven interior furniture. Also take care not to damage floor coverings.

Levelling The appliance should be located on a level surface. The two front feet can be adjusted to a maximum height of 910mm as required. To ensure that your appliance is standing level adjust the two front feet by turning clockwise or anticlockwise until the product is in firm contact with the floor.

Installing your cooker

Important

WARNING! THIS APPLIANCE MUST BE EARTHED AND MUST NOT BE INSTALLED ON A RAISED BASE!

Your cooker should have been checked to ensure that the voltage corresponds with the supply voltage, this is stated on the rating plate, which is situated on the plinth below the oven door.

The cooker must be connected by a qualified electrician to a suitable double-pole control unit with a minimum of 32A and a minimum contact clearance of 3mm, which should be fitted adjacent to (but not above) the cooker, in accordance with IEE regulations. The power supply cable should conform to BS6004. We recommend P.V.C. insulated twin and earth cable with a conductor size of 6mm². The maximum size of cable that can be used is 10mm².

The control unit should be easily accessible in the event of an emergency.

This appliance conforms to EN55014 regarding suppression of radio and television interference.

Connecting the Cooker

For access to the mains terminal block, for supply cable connection, it is necessary to remove the mains terminal cover, located at the lower right-hand side of the rear panel. Pass the cable through the cable clamp and connect to the appropriate terminals provided. Tighten the screws on the cable clamp and replace the cover.

No part of the appliance will operate unless the main control unit is switched **ON**.

Allow sufficient cable length for the cooker to be pulled out for cleaning, but do not let it hang closer than 50mm (2") to the floor. The cable can be looped if necessary, but make sure that it is not kinked or trapped when the cooker is in position.

Before Cooking

Before you cook for the first time, we recommend that you switch on each element in turn to burn off any odours remaining from manufacture. Simply operate each hob element and the grill on maximum for a few minutes, and the oven for approximately 30 minutes. Ensure that the room is well ventilated (eg. open a window or use an extractor fan) and that persons who may be sensitive to the odour avoid any fumes. It is suggested that any pets be removed from the room until the smell has ceased.

For your safety

When used properly your Belling Forum is completely safe, but as with any electrical appliance there are some precautions you must take in its use.

Never..

- Never allow anyone except an authorised Belling Service Agent to service or repair your cooker.
- Never remove any part of the cooker other than those intended in normal use, or attempt to modify the cooker in any way.
- Never use the cooker for commercial catering. It is designed for domestic use and for cooking food only.
- Never allow young children to operate or play with the cooker, as all surfaces get hot while in use.
- Never allow children to sit or stand on any part of the appliance.
- Never store items above a cooker that children may attempt to reach.
- Never use a chip pan or deep fat fryer more than 1/3 full of oil, or use a lid while frying, and do not leave a fryer unattended while cooking.
- Never operate the grill with the grill/top oven door closed. This may cause overheating of your cooker.
- Never line the shelves, floor, or sides of the oven or grill, with aluminium foil as overheating and damage may result.
- Never place materials which might catch fire, such as tea towels on the hob or elements, even when the cooker is not in use.
- Never allow aluminium foil or plastic to touch any hob element when it is hot.
- Never use an asbestos mat, trivet or rack of any kind under pans on the hob.
- Never store anything which might catch fire in the oven or grill.
- Never heat unopened containers.
- Never place flammable or plastic items on or near the hob.
- Never dry clothes on either hob or oven doors.
- Never store flammable liquids, aerosols, etc. in adjacent cabinetry.
- Never operate the grill when the ovens are set to cook automatically.
- Never use large preserving pans or fish kettles across two hotplates as this will damage the hob.

For your safety

Always..

- Always take care when touching any part of the cooker which may be hot. Use dry oven gloves when removing or replacing food or dishes. Care should be taken to avoid touching the heating elements inside the oven.
- Always stand back when opening the oven door to allow any build-up of heat or steam to disperse.
- Always keep the oven and grill doors closed when not in use to prevent accidents, but remember that the grill door must be kept open when grilling to prevent overheating.
- Always make sure that the roof, side and back panels, and shelves are fitted correctly before using the oven or grill.
- Always keep your cooker clean, as a build-up of grease or fat from cooking may be a fire hazard.
- Always switch off at the mains supply and allow the cooker to cool before cleaning your cooker.
- Always supervise children and pets, particularly when grilling, as exposed parts of the cooker may become hot.
- Always use suitable pans for the hob, and make sure that they are stable.
- Always keep handles away from the edge of the hob and any heat. For added safety you should consider using a suitable hob guard.
- Always make sure that all the controls are switched off when you finish cooking.
- Always remember that your cooker may stay hot for a time even after you have finished cooking.
- Always keep ventilation slots clear of obstructions.
- Always keep children away from cooker when cleaning at maximum oven setting.

Know Your Cooker

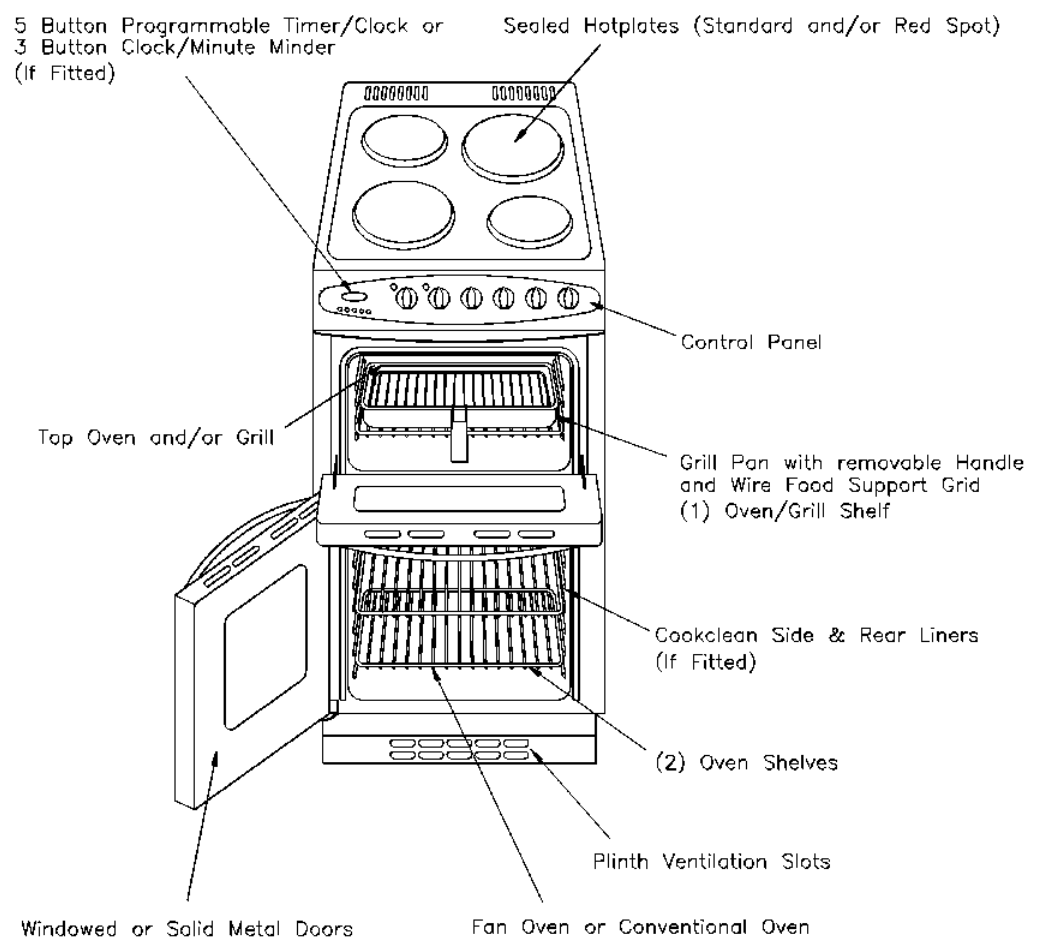

Using the timer

3 Button Clock/Minute Minder/Automatic cut-off

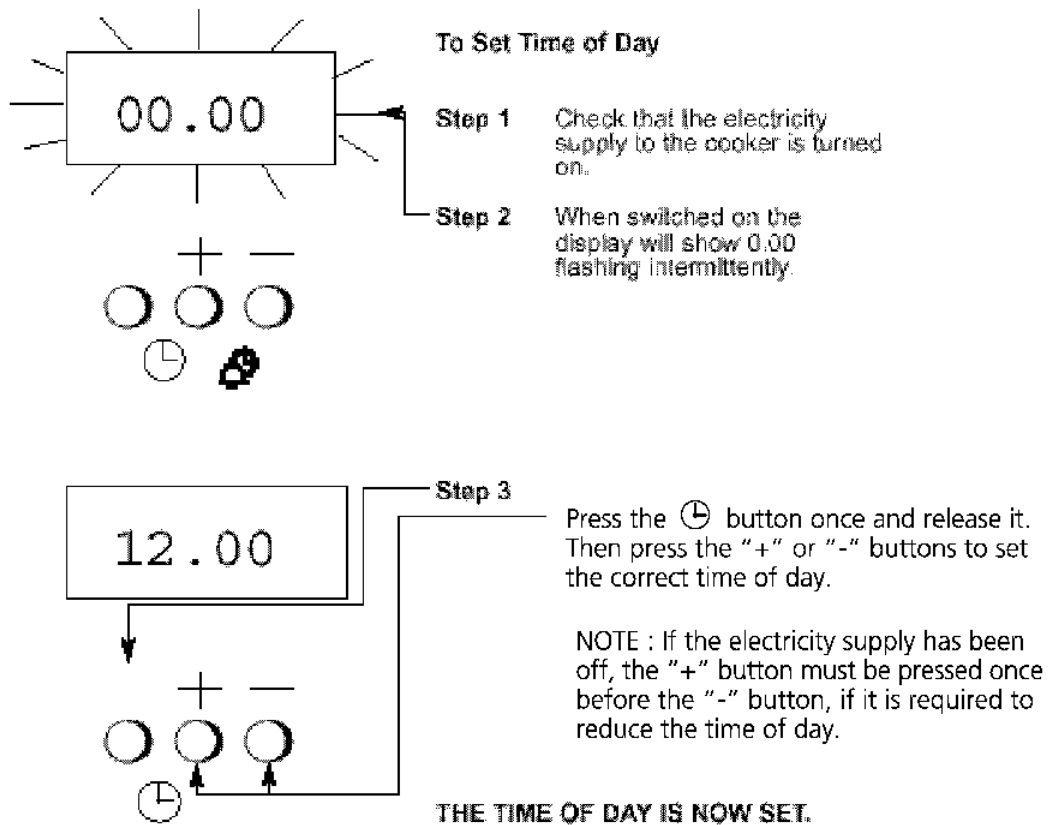

Minute minder operation/Automatic cut-off

To Set the Minute Minder

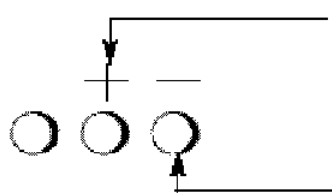
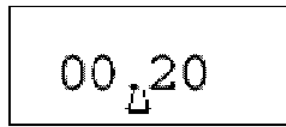

Step 1

Press the "+" button once and release it. Then press the "+" button again to set the required time. During setting the time adjusts in 10 second intervals up to a maximum of 99 mins 50 secs. The "+" and "-" signs are used for setting the required time.

At the end of the set time, a bleeping sound will be heard and the "bell" will disappear.

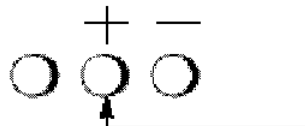
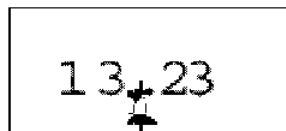

The bleeger can be cancelled by pressing the "+" or "-" buttons.

NOTE: If necessary the minute minder can be cancelled before the bleeper sounds.

- a) Press the "+" button
 - b) with the "+" button still held in, press the "-" button until "0.00" appears in the display window.
- Sometimes  symbol appears or disappears during setting operation. A tapping sound can also be heard. These are normal so must not be considered as a faulty.

If a temperature is selected for the main oven first the oven will switched off after the set period.

5 Button Clock/Programmer



The timer display is in 24 hour clock format.

Ensure that the correct time of day is always set before using your cooker.

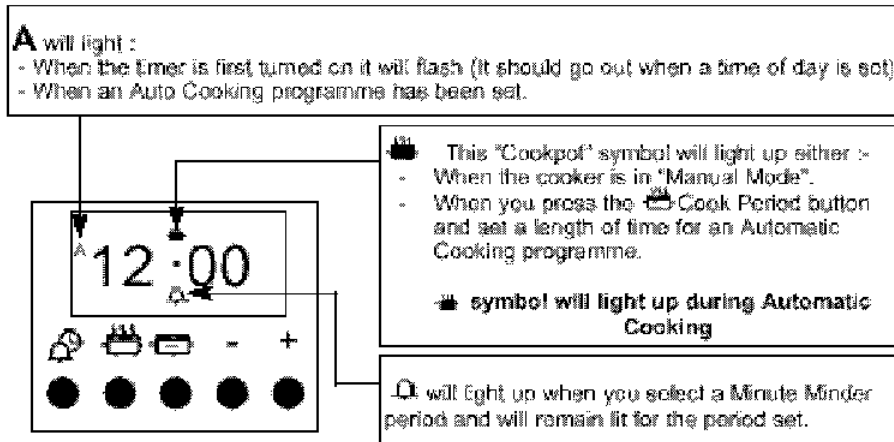

MINUTE MINDER



Here you can set a time period of up to 23 hours and 59 minutes that will count down.

When it reaches zero the timer will bleep.

e.g. If you set 20 minutes, the timer will start beeping 20 minutes later.



COOK PERIOD

Cook Period is the actual length of time for which, the timer will switch the oven(s) on as part of an "Automatic Cooking" programme.

e.g. If you set 2 hours, the food will be cooked for 2 hours.



END TIME

The time of day at which you want an automatic cooking programme to end.

e.g. If you set a cook period for 2 hours, and end time of 11:00. The timer will switch the oven(s) on at 9:00 and turn the oven(s) off at 11:00. You will hear a bleep at 11:00 to indicate that the automatic cooking programme has finished.

Notes

- When setting an automatic cooking programme you will need to set the oven control(s) to the required temperature(s) when you set the timer.
- If an automatic cooking programme has been set the oven(s) will only operate during the pre-programmed time.

+ and --

Used to adjust the various timer function settings.

- Used to adjust pitch of audible tone. (See **Clock and Automatic Timer Operation**).

Setting the Time of Day

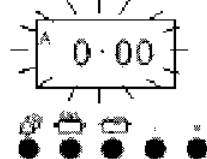



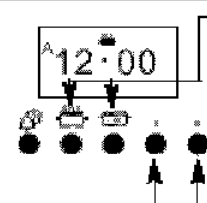

Step 1 Make sure all oven controls are turned **OFF**.

Step 2 Check the electricity supply to the cooker is turned **ON**.

When switched on the display will show **0.00** and the **A** symbol, both will be flashing.



Step 3 Press & hold in both the  cook period &  end time buttons together.

Step 4 With the  cook period &  end time buttons still held in, press either the **+** or **-** buttons to set the correct time of day.

Step 5 Release all the buttons simultaneously.

The time of day is now set and the  symbol will light up to show that the timer is in Manual Mode.

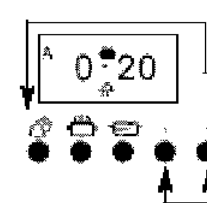

NOTE: To change the time of day repeat steps 3, 4 & 5 above.

Setting the Minute Minder



Step 1 Ensure the time of day is set correctly.

Step 2 Press and hold the  minute minder button.

Step 3 With the  button still held in set the required  minute minder time using **+** and **-** buttons.

A  symbol will light up.

Step 4 Release all buttons and the timer display will revert back to the time of day.

The  symbol will remain lit to signify that a minute minder period has been set.

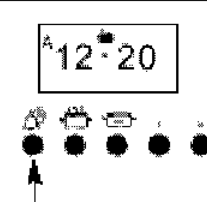

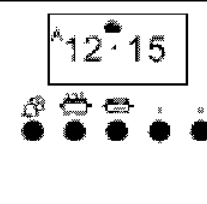

At the end of the set time a beeping sound will be heard and the  symbol will go out. The beeping sound will continue for several minutes unless cancelled (See **Step 5**).

Step 5 To cancel the beeping sound press the  minute minder button. The time display will revert back to the time of day after the button is released.



To cancel the minute minder before the minute minder period has finished.

Step 1 Press the  minute minder button.

Step 2 Press the **-** button until 0.00 and the  symbol appears in the display window.

Step 3 To cancel the beeping sound press the  minute minder button.

Note When the minute minder has been set, the time remaining can be checked at any time by simply pressing the  minute minder button.

Automatic Cooking Programmes

If your appliance has two ovens

The main oven only is programmable.

When the timer has been set for one oven it is possible to use the top oven manually during the same automatic programme.

There are two automatic cooking programmes that can be selected using your timer:

- (a) To set the timer to switch the oven ON and OFF automatically.
- (b) To set the timer to switch on immediately and OFF automatically after a set cook period.

(a) To set the timer to switch the oven ON and OFF automatically.

This allows you to cook at a specific time for a chosen period before the oven switches off automatically.

Step 1 Check that the correct time of day is set. If not follow instructions for setting the time of day.

Step 2 Place food onto the correct shelf position in the oven and close the oven door.

Step 3 Press and hold the cook period button. The display will read 0.00 with the cookpot symbol lit.

Step 4 With the cook period button still held in set the required cook period using + and - buttons.

Release the buttons and the timer display will revert to the time of day with the **A** symbol and symbol lit.

Step 5 Press and hold the and time button. The display will read the earliest possible time for the cook period that you have set above.

Step 6 With the and time button still held in, use the + and - buttons to set the end time. i.e. The time you require the oven to switch off.

Release all the buttons and the timer will revert back to the time of day.

The **A** symbol will remain lit to signify that an automatic cooking programme has been set. The symbol will go out.

When the auto cook programme starts the symbol will then light up again.

Step 7 Turn the oven control to the required temperature.

At the end of the automatic cook period the **A** symbol will flash and an intermittent beeping sound will be heard. The symbol will go out.

The beeping sound will continue for several minutes unless cancelled (see step 8). The **A** symbol will continue to flash until the timer is returned to manual operation (see below).

Step 8 Press the cook period button to cancel the beeping sound.

Step 9 Turn the oven control(s) to the OFF position.

Step 10 Press the cook period and end time buttons together to return the oven(s) to manual operation. The **A** symbol will go out and the symbol will light up.

Notes

When cooking automatically the cook period can be checked at any time by simply pressing the cook period button and the end time by pressing the end time button. To cancel the auto cooking programme before or after auto cooking starts, press the cook period and end time buttons together. This will return the ovens to manual operation.



(b) To set the timer to switch ON immediately and OFF automatically after a set cook period.

Step 1 Check that the correct time of day is set. If not follow instructions for setting the time of day.

Step 2 Place food onto the correct shelf position in the oven and close the oven door.

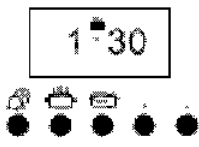
Step 3 Turn the oven control to the required temperature.



Step 4 Press and hold the  cook period button, the display will read 0.00 and the  symbol will light up.

With the  cook period button still held set the required cook period using the **+** and **-** buttons, the **A** symbol will light up, e.g. 1 hour 30 minutes.

Note: The cook period is the length of time the food requires to cook.

Step 5 Release all buttons.

The timer display will revert to the time of day with the **A** and  symbols remaining lit.

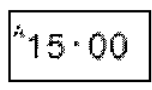

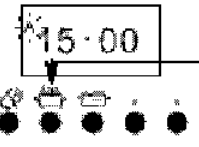

At the end of the cook period the **A** symbol will flash and an intermittent beeping sound will be heard. The  symbol will go out. The beeping sound will continue for several minutes unless canceled (see **Step 6**). The **A** symbol will continue to flash until the timer is returned to manual operation (see below).



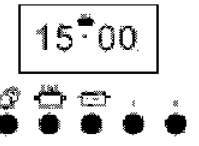

Step 6 Press the  cook period button to cancel the beeping.



Step 7 Turn the oven control(s) to the OFF position.

Step 8 Press the  cook period and end time buttons together to return the cooker to manual operation. The **A** symbol will go out and the  symbol will light up.

When cooking automatically the cook period can be checked at any time by simply pressing the  cook period button. To cancel the auto cooking programme before or after automatic cooking starts, press the  cook period and  end time buttons together. This will return the cooker to manual operation.

Using the Hob

Hotplates

Hotplate Controls The controls set the hotplates at six preset power levels, indicated by the numbered markings on the control panel, intermediate settings **cannot** be obtained.

Use of Hotplates Each control can be used to select one of six temperature settings from a minimum at position 1 to a maximum at position 6. For normal cooking, after having placed the pan on the required hob position, set the control knob to maximum (6); wait until boiling point is reached, then set the knob to a lower position as required. Red spot plates give faster boiling times. (See chart below for guide to control settings.)

Control Settings This table is provided only as a guide – settings also depend on the type of pan used and the quantity of food.

Knob Position	Type of Food
1	To melt butter, chocolate, etc.
1 or 2	To heat food gently. To keep small amounts of water simmering. To heat sauces, containing egg yolks and butter. To simmer: stews, meat, fish, vegetables, fruit.
3	To heat solid and liquid foods. Keep water boiling. Thaw frozen foods. Make 2-3 egg omelettes.
4 or 5	To cook foods, just above simmering. To maintain 'rolling' boil for preserve making.
5 or 6	To seal meat and fry fish.
6	Frying potatoes. Bringing water to the boil. Deep fat frying. Dissolve sugar for preserve making.

Choosing your Utensils

For best results we recommend the use of good quality saucepans with smooth flat bases. Aluminium pans with coloured vitreous enamelled bases absorb heat and are therefore more efficient in use. Almost equally as good are saucepans with a thick machined aluminium base. If using enamelled steel or cast iron pans, ensure that they have good smooth flat bases as otherwise the heat will not be distributed evenly and damaging heat spots may be created. **Never** use recessed or ridged base utensils. Ideally the base of saucepan should be approximately the same size as the heating area, up to a maximum of 254mm (10").

REMEMBER

1. Purchasing a new pan will not necessarily mean it will have a flat base, always check before buying.
2. Using the correct pans and utensils will result in maximum contact with the hob and maximum efficiency as with any type of electric hob.

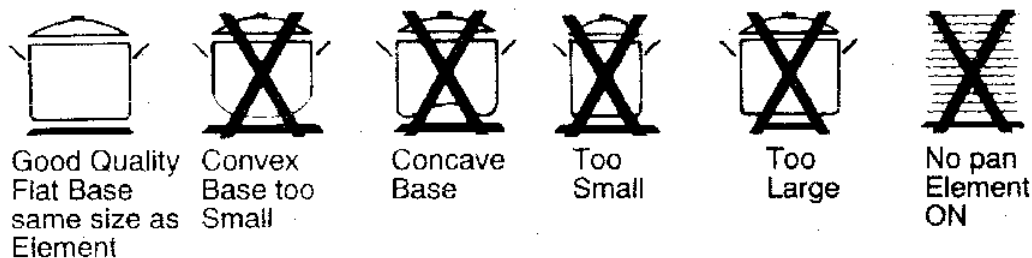

SAFETY REQUIREMENTS FOR DEEP FAT FRYING

IMPORTANT:

Deep Fat Frying

As there could be some fire risk attached to the heating of oil, particularly for deep fat frying, cooking utensils containing oil must not be left unattended (e.g. to answer the telephone).

In the unfortunate event of a fire it will assist in smothering the flames if the pan lid is replaced, and the electricity supply is switched **OFF**.

1. Use a deep pan, large enough to completely cover the appropriate heating area.
2. Never fill the pan more than one-third full of fat or oil.
3. Never leave oil or fat unattended during the heating or cooking period.
4. Do not try to fry too much food at a time, especially frozen food. This only lowers the temperature of the oil or fat too much, resulting in greasy food.
5. Always dry food thoroughly before frying, and lower it slowly into the hot oil or fat. Frozen foods, in particular, will cause frothing and spitting, if added too quickly.
6. Never heat fat, or fry, with a lid on the pan.
7. Keep the outside of the pan, clean and free from streaks of oil or fat.

Safety advice in case of a chip pan fire

In the event of a chip pan fire or any other pan fire.

1. **TURN OFF THE COOKER AT THE WALL SWITCH.**
2. **COVER THE PAN WITH A FIRE BLANKET OR DAMP CLOTH**, this will smother the flames and extinguish the fire.
3. **LEAVE THE PAN TO COOL FOR AT LEAST 60 MINUTES BEFORE MOVING IT.** Injuries are often caused by picking up a hot pan and rushing outside with it.

NEVER USE A FIRE EXTINGUISHER TO PUT OUT A PAN FIRE as the force of the extinguisher is likely to tip the pan over.

Never use water to extinguish oil or fat fires.

Using the grill

Parts may become hot when the grill is in use, children must be kept away. As a safety feature, the thermostat will prevent the grill overheating if the door is closed.

ALWAYS ENSURE THE DOOR IS OPEN WHEN GRILLING

- 1 Open the grill door.

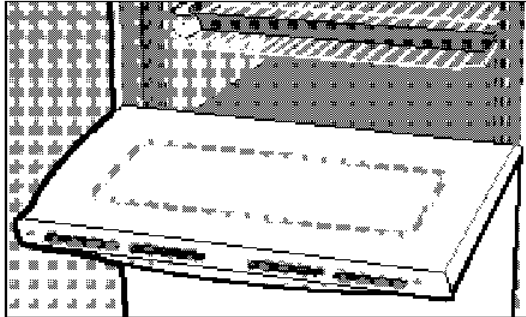

- 2 Turn the grill on by turning the grill control knob to maximum or to position 6 (for grill only models) and allow to preheat for around 5 minutes.
 - 3 Select the temperature rotating the knob to the temperature required.
- **Only use the middle and bottom rack position for grilling. Do not use the top position.**
 - Ensure the food is correctly positioned under the grill element.
 - Food which requires browning only should be placed under the hot grill, either in the grill pan, or on the floor of the grill compartment, according to the depth of the dish. The grill pan wire grid can be removed.
 - Do not line the grill pan with aluminium foil.
 - Plates and dishes placed on the floor of the grill compartment will be heated when the main oven is in use.
 - Do not switch on the grill when using the compartment for storage.

Grilling Guidelines

Use the following chart for guidelines.

For thicker foods requiring longer cooking, turn the control to a lower setting after the initial sealing on both sides. The thicker the food, the lower the control should be set. When grilling thicker food, the grill rack should be turned over to its lowest position.

Food	Grill Setting	Approximate Cooking time
Toasting of Bread products	6 or 230°C	3 - 10 mins.
Small cuts of meat, sausages, bacon, etc.	5-6 or 220-230°C	15 - 20 mins.
Chops etc. Gammon steaks Chicken pieces	5-6 or 220-230°C	20 - 25 mins. Wire food support used in upturned position for chicken.
Fish: Fingers Whole Fillets	5 or 220°C	10 - 20 mins. Whole fish and fillets placed in the base of the grill pan.
Fish in breadcrumbs	5 or 220°C	15 - 20 mins.
Pre - Cooked potato products	5 or 220°C	15 - 20 mins.
Pizzas	5 or 220°C	12 - 15 mins. in the base of the grill pan.
Browning of food	6 or 230°C	8 - 10 mins. Dish placed directly on the base of the grill compartment

Use of Grill Pan Handle

Warning! Always use an oven glove to protect your hand when using the grill as all metal parts can become very hot.

The grill pan has a detachable handle. Make sure the handle is securely located between the raised profiles across the front of the grill pan. See the diagrams for fitting the handle. To remove the handle, reverse the sequence of operations.

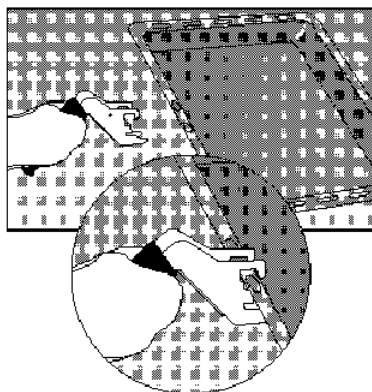

Always take care not to touch hot surfaces when using the grill pan handle. Ensure when using the grill pan handle that it is centralised and secure. Do not leave the handle in position when grilling. If the handle is left in position when grilling, it will get very hot.

Using the top oven

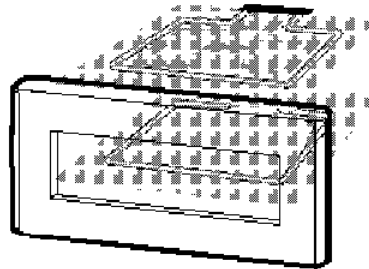

As an oven
door closed
(lower element is concealed)

Use of the oven

- 1 Turn the oven on by rotating the top oven control knob clockwise.
 - 2 Select the temperature in the oven by rotating the knob to the temperature required.
 - 3 The amber temperature indicator light on the control panel will glow until the pre-set temperature set is reached.
 - 4 Once the temperature has been reached, the amber light will go off and then cycle on and off to maintain the pre-set temperature.
- **Take care when opening the door. Let steam and hot air escape before removing the food.**

Shelf Positions

The shelf positions are counted from the bottom runner up as shown below.

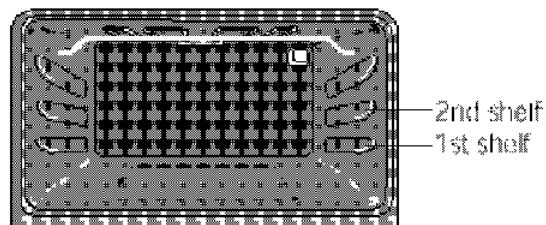

Top oven cooking guide

FOOD	COOKING TEMPERATURE °C	TIME	SHELF POSITION
BEEF	170-180	30 mins/450g + 30 mins	1
LAMB	180-190	30 mins/450g + 30 mins	1
PORK	170-190	40 mins/450g + 40 mins	1
POULTRY	170-190	25-30 mins/450g +25 mins	1
CASSEROLES	140-160	1.5/2 hours dependent on quantity	1
FRUIT CAKE	140-160	Time dependent on size	1-2
SMALL CAKES	160-180	20-25 mins	1
VICTORIA SANDWICH	160-180	20-25 mins	1

Using the Main Oven

Shelf Positions

The shelf positions are counted from the bottom runner up as shown below.

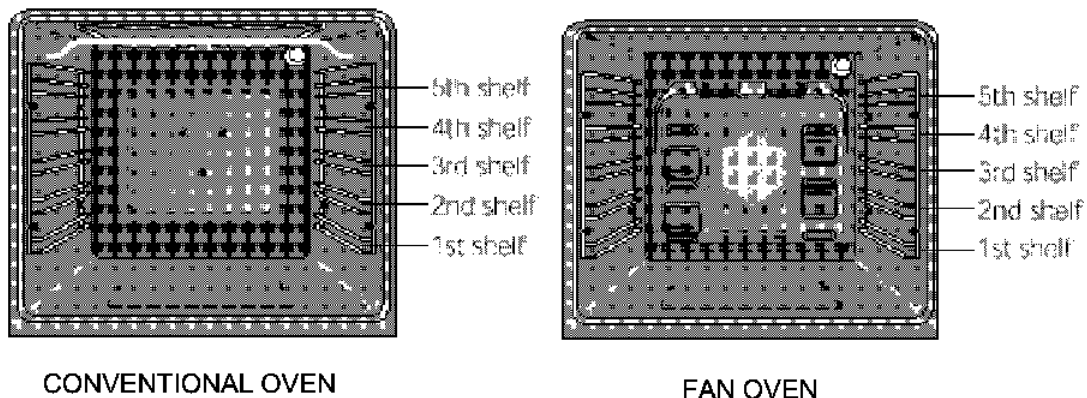

Special notes for fan ovens:

As a fan oven heats up more quickly and generally cooks food at a lower temperature than a conventional oven, preheating the oven is often unnecessary. However, food such as bread, scones, Yorkshire pudding, do benefit from being placed in a pre-heated oven.

The temperature charts are a guide only, giving approximate cooking temperatures and times. To suit personal taste and requirements it may be necessary to increase or decrease the temperature by 10°C.

Unless otherwise indicated in the charts, food is placed in a cold oven, ie. without pre-heating. If food is placed in an already hot oven, the suggested cooking time should be reduced, depending on the type and quantity of food being cooked.

An additional shelf can be purchased from Belling Spares (tel. 01709 579907 quoting ref. FS313001) if required for batch baking.

Use of the oven

- 1 Turn the oven on by rotating the oven control knob clockwise.
- 2 Select the temperature in the oven by rotating the knob to the temperature required.
- 3 The amber temperature indicator light on the control panel will glow until the pre-set temperature set is reached.
- 4 Once the temperature has been reached, the amber light will go off and then cycle on and off to maintain the pre-set temperature.

Ensure you stand back from the appliance when opening the oven door to allow any build up of steam or heat to escape.

- Check food is thoroughly cooked and is piping hot before serving.
- When cooking using both shelves, rotate the food to ensure even cooking/baking results.

Important Note (Conventional Oven)

The conventional oven has an element situated under the floor of the cavity. **DO NOT STORE PANS IN THE CAVITY WHEN THE OVEN IS IN USE!** To avoid the possibility of a fire hazard, keep the cavity clean and free from build up of fat and grease.

Oven temperature chart

This chart is for guidance only, follow food manufacturers recommendations whenever available.

Temperature conversion

The oven temperature control knob is marked in degrees Celsius (sometimes called Centigrade). This chart should help when recipes show °F.

Celsius °C	Fahrenheit °F
70	150
80	175
100	200
110	225
120	250
140	275
150	300
160	325
180	350
190	375
200	400
220	425
230	450
250	480

Conventional Oven Cooking Guide

FOOD	COOKING TEMPERATURE °C	TIME	SHELF POSITION
BEEF	180-190	30 mins/450g + 30 mins	2
LAMB	180-190	30 mins/450g + 30 mins	2
PORK	170-180	40 mins/450g + 40 mins	1-2
POULTRY	180-200	25-30 mins/450g +25 mins	1-2
CASSEROLES	140-160	1.5/2 hours dependent on quantity	1-2
FRUIT CAKE	140-160	Time dependent on size	2-3
SMALL CAKES	160-180	20-25 mins	4
VICTORIA SANDWICH	160-180	20-25 mins	1

Fan Oven Cooking Guide

FOOD	COOKING TEMPERATURE °C	TIME	SHELF POSITION
BEEF	160-180	20-25 mins/450g + 20 mins	2
LAMB	160-180	25 mins/450g + 25 mins	2
PORK	160-180	25 mins/450g + 25 mins	1-2
POULTRY	160-180	18-20 mins/450g +20 mins	1-2
CASSEROLES	140-150	1.5/2 hours dependent on quantity	1-2
FRUIT CAKE	130-140	Time dependent on size	2-3
SMALL CAKES	160-180	15-25 mins	4
VICTORIA SANDWICH	160-180	20-25 mins	1

Care and Cleaning

TURN OFF COOKER AT MAIN WALL SWITCH BEFORE CLEANING

Before switching on again, ensure that all controls are in the **OFF** position.

Refer to instructions below for cleaning the 'Cookclean' removable side oven panels.

Sealed Hotplates

The cleaning of sealed hotplates should be done when they are cold, using a soap filled pad, following the grain of the hotplate.

This will ensure that any stubborn, burnt on spillages are removed. Wipe over with a damp clean cloth, making sure that all the cleaner has been removed. Finally, turn on heater to warm for a few minutes, then smear with a little cooking oil to provide a protective coating.

The stainless steel hotplate trim will discolour during normal use and can be cleaned using a cream cleaner or a stainless steel cleaner.

Vitreous Enamel Hob Surround

Clean with a cloth wrung out in soapy water. Stubborn stains can be removed with a cream, paste or liquid cleaner, or by gently rubbing with liberally soaped, very fine steel wool pads.

Control Panel

Wipe over the control panel with a damp cloth and polish with a dry cloth. **Do not use** oven cleaners or aerosols scouring pads or abrasive powder for cleaning the plastic knobs as damage will occur.

How 'Cookclean' Oven Liners Work

The surfaces of the 'Cookclean' oven liners are treated on the mottled face with a special vitreous enamel which absorbs cooking soils at temperatures of 220°C or above, the special surface enables these soils to be slowly destroyed. The higher the temperature the more effective it is. In most cases normal cooking operation at this temperature will permit this cleaning operation to proceed during cooking. However if higher cooking temperatures are not used regularly it may be necessary, to prevent heavy soiling, to run the oven at a higher temperature setting of 230°C for a couple of hours. This may be necessary once a month or once every two or three months, depending on the type and amount of oven cooking.

'Cookclean Panels'

It should not normally be necessary to clean the 'Cookclean' panels in water. If the user feels it is desirable to do so, remove the rod shelf and the side panels and wash them in warm soapy water, followed by rinsing in clear water.

Do not use enzyme/biological washing powder, harsh abrasives or oven chemical cleaners of any kind.

Do not rub the surface dry as it can damage the 'Cookclean' finish. After cleaning, replace the panels immediately and run the oven at maximum setting for about 30 minutes to prevent deterioration of the enamel.

Oven & Grill compartments

Remove the grill/meat pan and grid. It is best to wash these items immediately after use to prevent stains from being burnt on when used again.

Wipe around the oven or grill compartment, removing stubborn stains with a fine soap impregnated steel wool pad. Harsh abrasives should be avoided.

Remove the rod shelf for washing at the sink. Use a fine steel wool soap pad for removing stubborn stains from the rod shelf and floor of the oven. Take care during cleaning not to damage, bend or dislodge from the supporting clips the thermostat dial which is across the back of the oven just below the roof in the oven compartment.

Oven and Grill Door and Handles

Wipe over the door outer panel with a cloth wrung out in hot soapy water, then after wiping with a cloth wrung out in clear water, dry with a soft clean cloth.

Do not use scouring pads or abrasive powder which may scratch the surface.

Take care during cleaning not to damage or distort the Door Seal. Do not lift the Door Seal from the Oven Front Frame, if necessary remove the seal by carefully unhooking the corner clips.

N.B. Care must be taken that Rating Label edges are not lifted during cleaning and furthermore that the lettering is not blurred or removed .

Only use oven cleaners which carry the Vitreous Enamel Development Council's Approvals symbol, and always follow the manufacturers instructions for use.

Models with removeable inner glass panels

When you wish to clean the interior glass of the oven door, use a screwdriver to remove the top and bottom washers that secures the interior glass to the door, remove the glass with care.

Clean as above, but do not use house hold detergents, bleach, scouring pads or rust removers. After drying, position the gasket back into its place. Reinstall the glass panels carefully preventing sudden shocks.

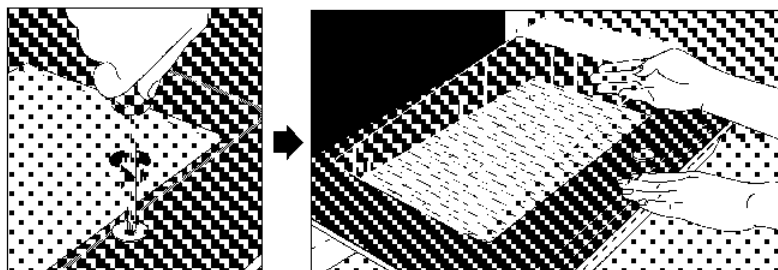

* If low emissive glass is fitted, ensure the printed side is facing outwards.

Replacement of Oven Lamps

WARNING: ISOLATE COOKER FROM SUPPLY BEFORE REPLACING LAMP.

Open the oven door and remove the rod shelves. Use a thick cloth to grip the light glass dome, which can be found in the upper right hand corner, unscrew anti-clockwise and lift out. Reach into the aperture with thick cloth, and unscrew the faulty lamp anti-clockwise. Fit replacement lamp (15W or 25W 300°C SES), refit glass lens.

The oven lamp is not covered by the guarantee.

A new lamp may be obtained from our Spares Department by calling:-01709 579907.

Something Wrong with your Cooker?

Before contacting your Belling approved Service Centre/Installer, check the problem guide below; there may be nothing wrong with your cooker.

Problem	Check
Slight odour or small amount of smoke when using the cooker for the first time.	This is normal and should cease after a short period.
Sinking of cakes	The following may cause cakes to sink: 1. Cooking at too high a temperature. 2. Using normal creaming method with soft margarine.
Over/Under cooking Fast/Slow cooking	Refer to the cooking times and temperatures given in the oven temperature charts, however, it may be necessary to increase or decrease temperatures by 10°C to suit personal taste. Do not use oven/meat pans greater than 56mm (2 1/4 ") in height.
Grill not working	Grill will not work unless the grill door is in the grilling position. (see grilling section)
Nothing works	Is the main cooker wall switch turned on?
Oven light does not work (if fitted)	Bulb has blown

*******Customer Care Centre*******

In case of difficulty within the UK or Northern Ireland please call, having the model number and serial number to hand:

Opening Hours for Customer Care Centre

Monday to Friday	8am – 8pm
Saturday	8:30am – 6pm
Sunday	10am – 4pm

For Belling Customer Helpline please call

0151 432 7999

For Belling Service please call

0151 432 7999

For Belling Spares please call

0151 432 7910

Model No

--	--	--	--	--	--	--	--	--	--

Serial No

--	--	--	--	--	--	--	--	--	--



Glen Dimplex Cooking Limited Stoney Lane
Prescot Merseyside L 35 2X W

